

Lon, BACnet, Proprietary?

David Witherspoon

Honeywell

Agenda

Honeywell

- **Introductions**
- **LON**
- **BACnet**
- **Proprietary**
- **WEBs**
- **WEBs Security**

Introductions

Honeywell

LON

Honeywell

- **LONWORKS**
 - The overall technology including the microprocessor, the protocol, and the entire network of devices, manufactured by the Echelon Corporation

- **LONTALK**
 - The protocol used by LONWORKS products
 - Conforms to the OSI 7 layer protocol stack

Internet / Intranet IP Backbone

- Internet to WEBs Panels (JACE) can be used to create one network by connecting remote locations over IP channels
- LNS Server is not required for routing packets
- WEBSupervisor may be used to synchronize message delivery across wide area networks

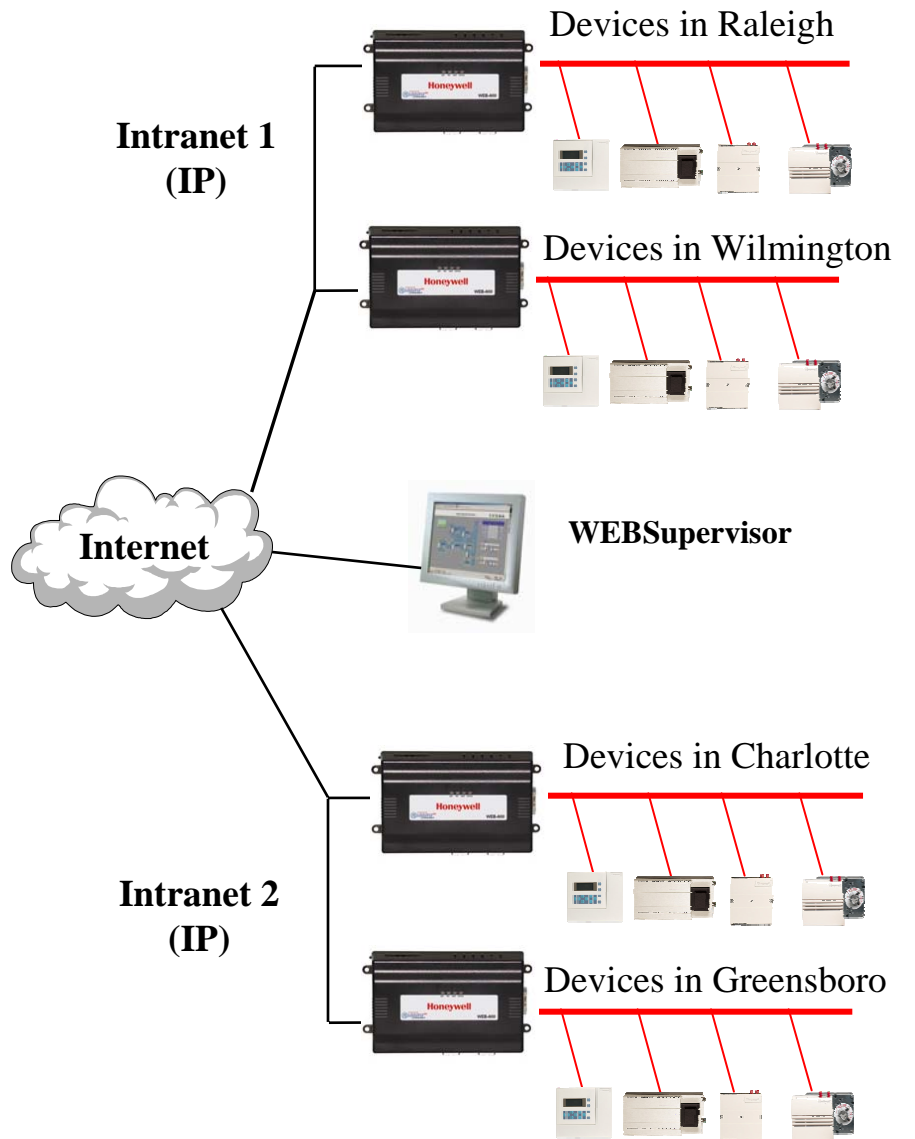



- **LonMark Association**

- **An independent association of manufacturers defining a common set of guidelines for assurance of interoperability between different manufacturers of LonMark devices**

- **LonMark Committees**

- **HVAC, Industrial, Network Tools, Lighting, Elevator, System Integrators, Fire, Lighting, Utility**



- **What is a profile?**

A committee approved network interface to an application representing mandatory and optional network variables

- **Why is it important?**

By using a profile you can guarantee the manufacturer includes the mandatory network variables to enable interaction between devices



- **Without profiles you are dependent on matching network variable types**
- **Different manufacturers may use different variable types to describe the same type of data which makes integration difficult**
- **Example: two VFD manufacturers use two different variable types to define the drive speed. With profiles, this practice is eliminated**



- **Verify LONMARK approval**
 - **LONMARK approval gives you a level of confidence that devices will communicate and interact properly**
 - **Easy to Specify**

BACnet

Honeywell

Definition



- **BACnet[®] is:**
 - **A Data Communication Protocol for Building Automation and Control Networks**

- **Developed by ASHRAE**
 - **8 Years to develop**
 - **Published in 1995**

- **Developed to Promote “Interoperability”**

For more information about BACnet, see www.bacnet.org.

What Is BACnet?



- It is a specification.
- It applies to all building systems.
- It provides a model for creating interoperable building automation systems.
- It defines objects that represent data and control functions.

What Is BACnet?



- It defines services used for requesting data and responding to those requests.
- Its multiple data-link layer definitions support flexible and cost-effective networks.
- It supports creation of large systems through internetworking.

Communication Options

- **BACnet IP**
- **BACnet Ethernet (8802-3)**
- **Master Slave/Token Passing (MSTP)**
- **Point to Point (PTP)**

Internet / Intranet IP Backbone

- Internet to WEBs Panels (JACE) can be used to create one network by connecting remote locations over IP channels
- BACnet Server is not required for routing packets
- WEBSupervisor may be used to synchronize message delivery across wide area networks

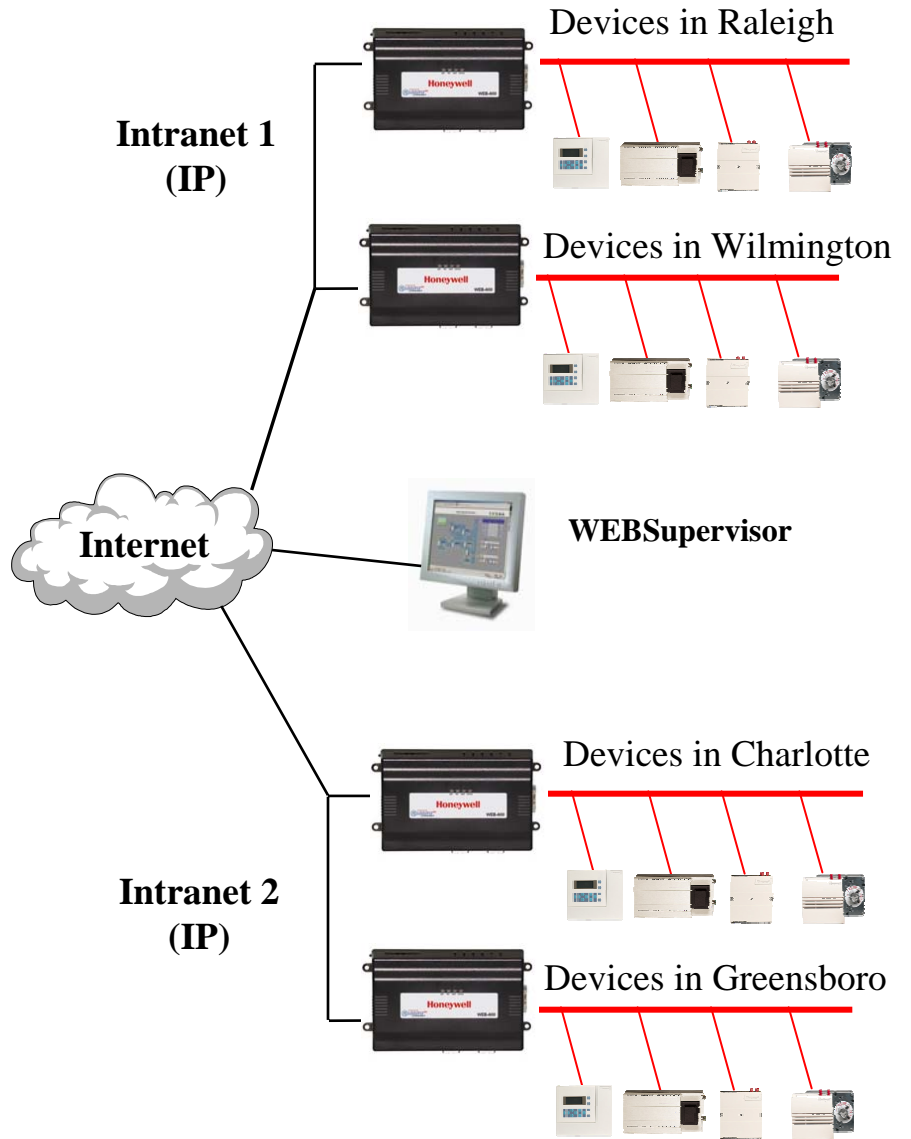

How Does BACnet Work?



BACnet divides interoperability into three distinct areas and defines methods and standards for each.

- **Defines rules for LANs and internetworks or *Transport Systems*.**
- **Data representation or *Objects*.**
- **Data exchange methods or *Services*.**

Device Profiles

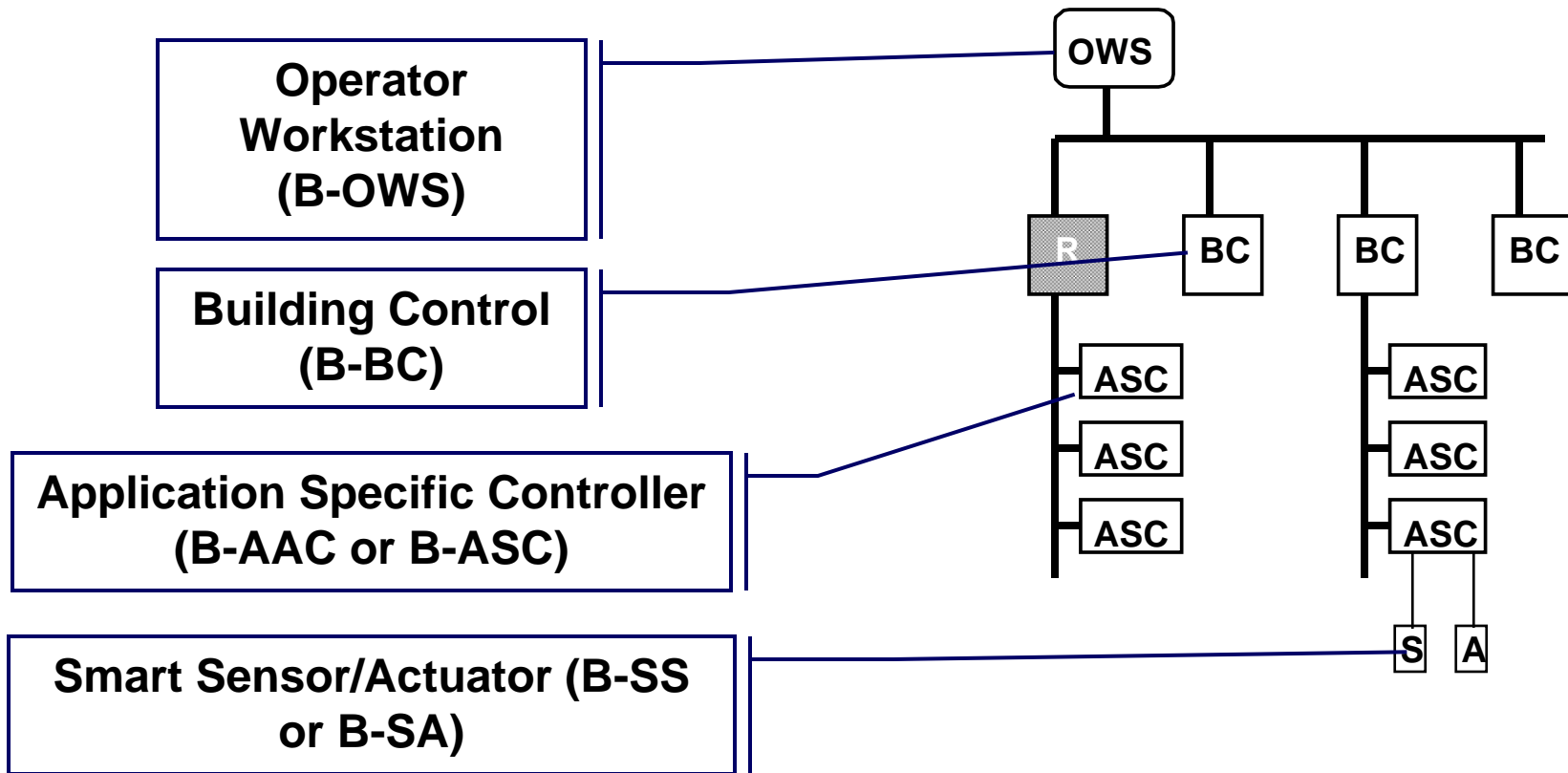

Proprietary

Honeywell

- **Typically simpler to program**
- **Limited integration capability**
- **At controller level, there is not a significant difference between “Open” and Proprietary Systems – other than communication protocols.**
- **Systems have been on the market for years and proven their reliability.**
- **Limited contractor choices**

EXCEL5000 OPEN™ SYSTEM ARCHITECTURE

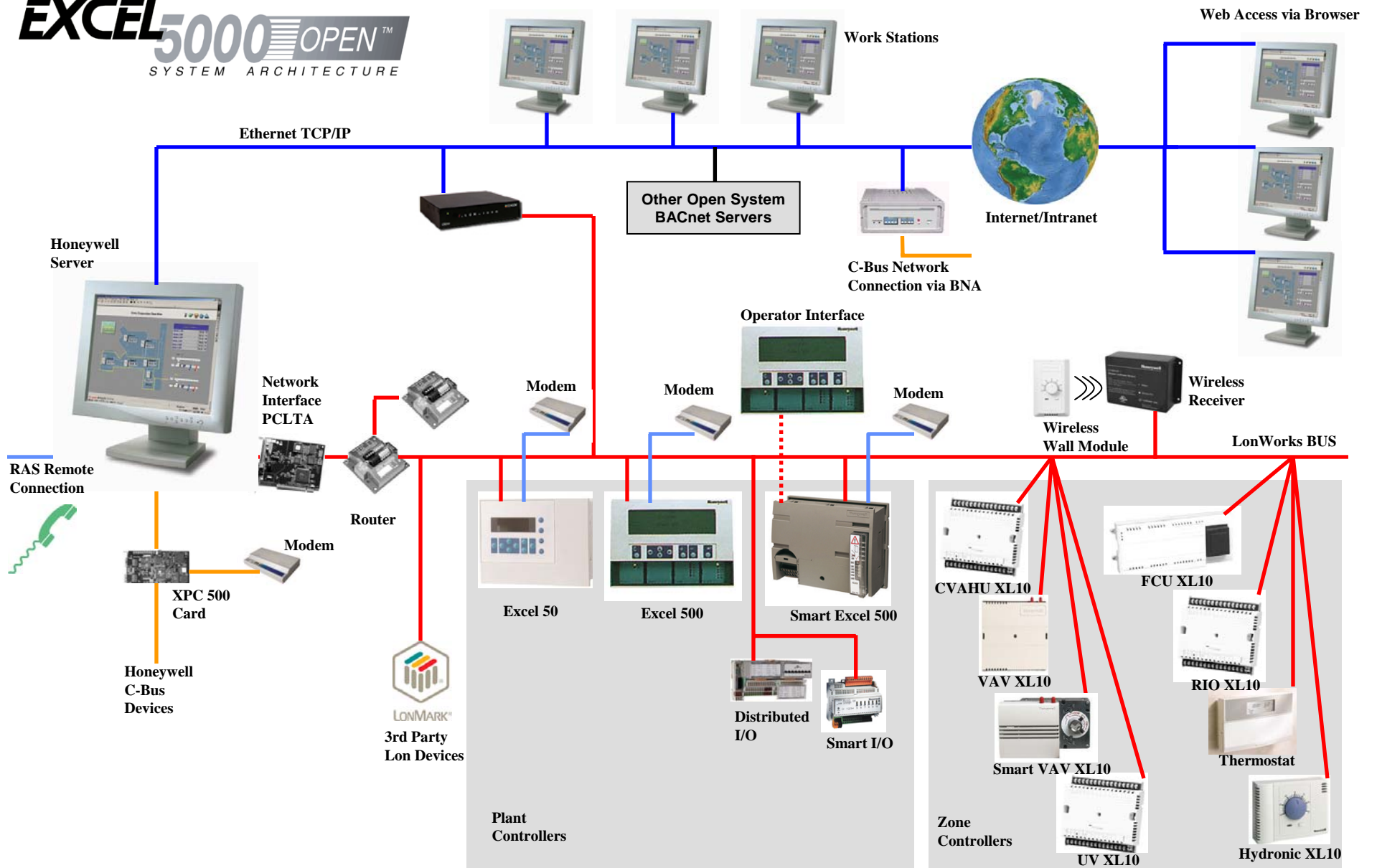

Protocol Summary

Honeywell

US Market position

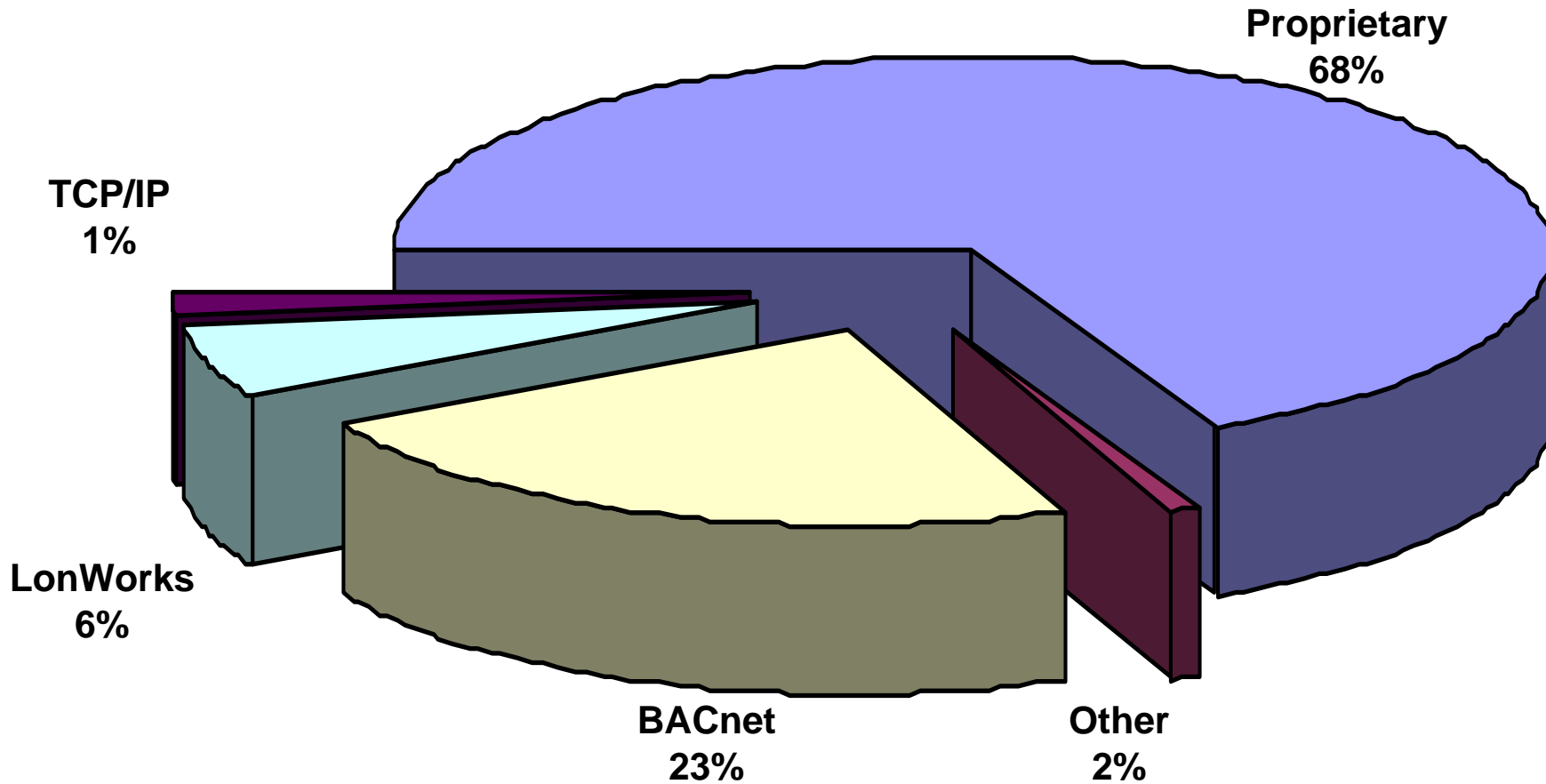

WEBS

Honeywell

- **Our Business is Building Software Used to Build Software – *Our Tools are Used to Create End Applications that a User Experiences***
- **Niagara is a Foundation that Makes it Easier to Build Internet-Enabled Automation Products and Device-to-Enterprise Applications**
- **At its Core, Niagara is About Modeling – Modeling the Data and Behavior of Devices and Systems**

Enterprise Architecture

Honeywell

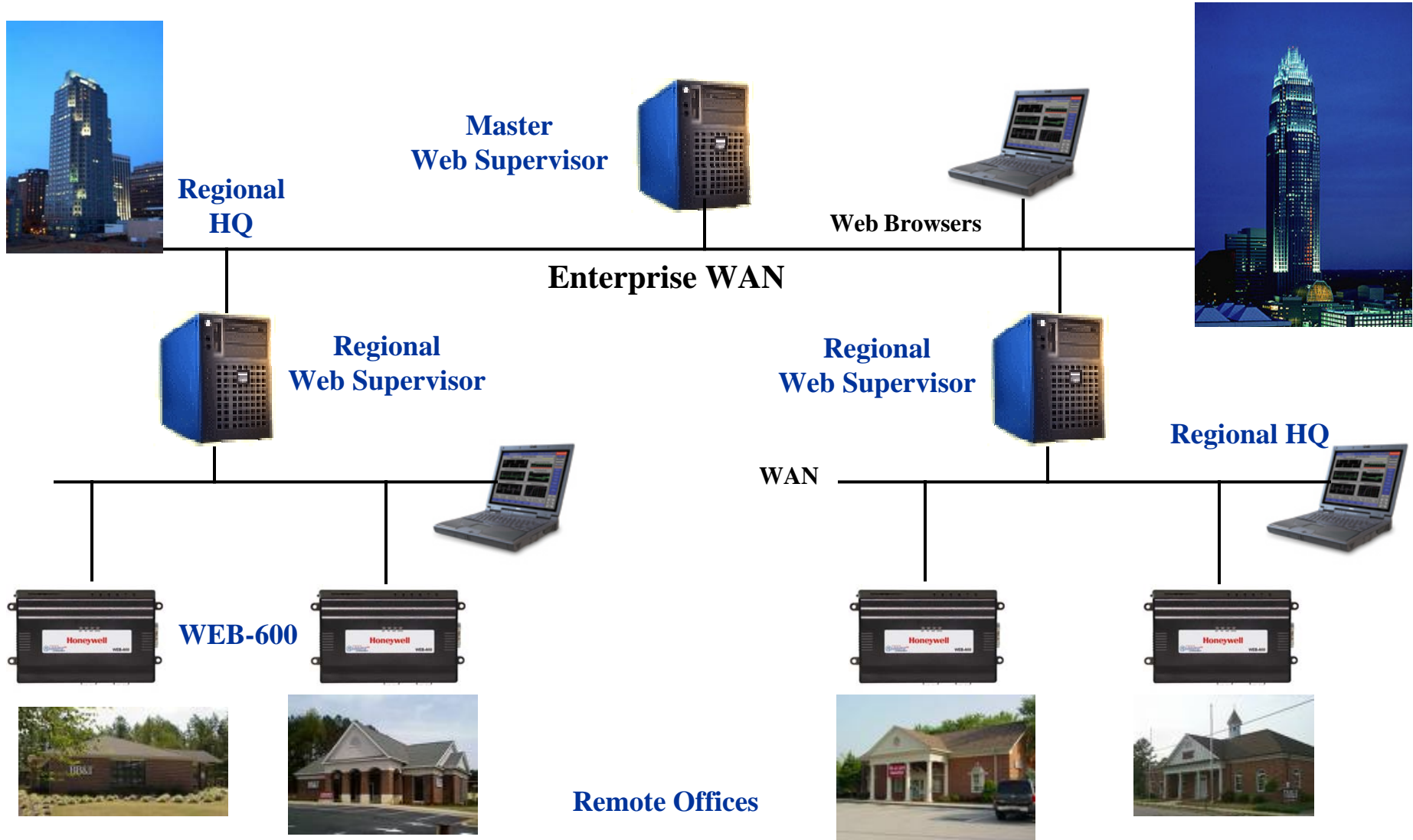

Typical Building Architecture



Open Web Enabled Framework

Honeywell

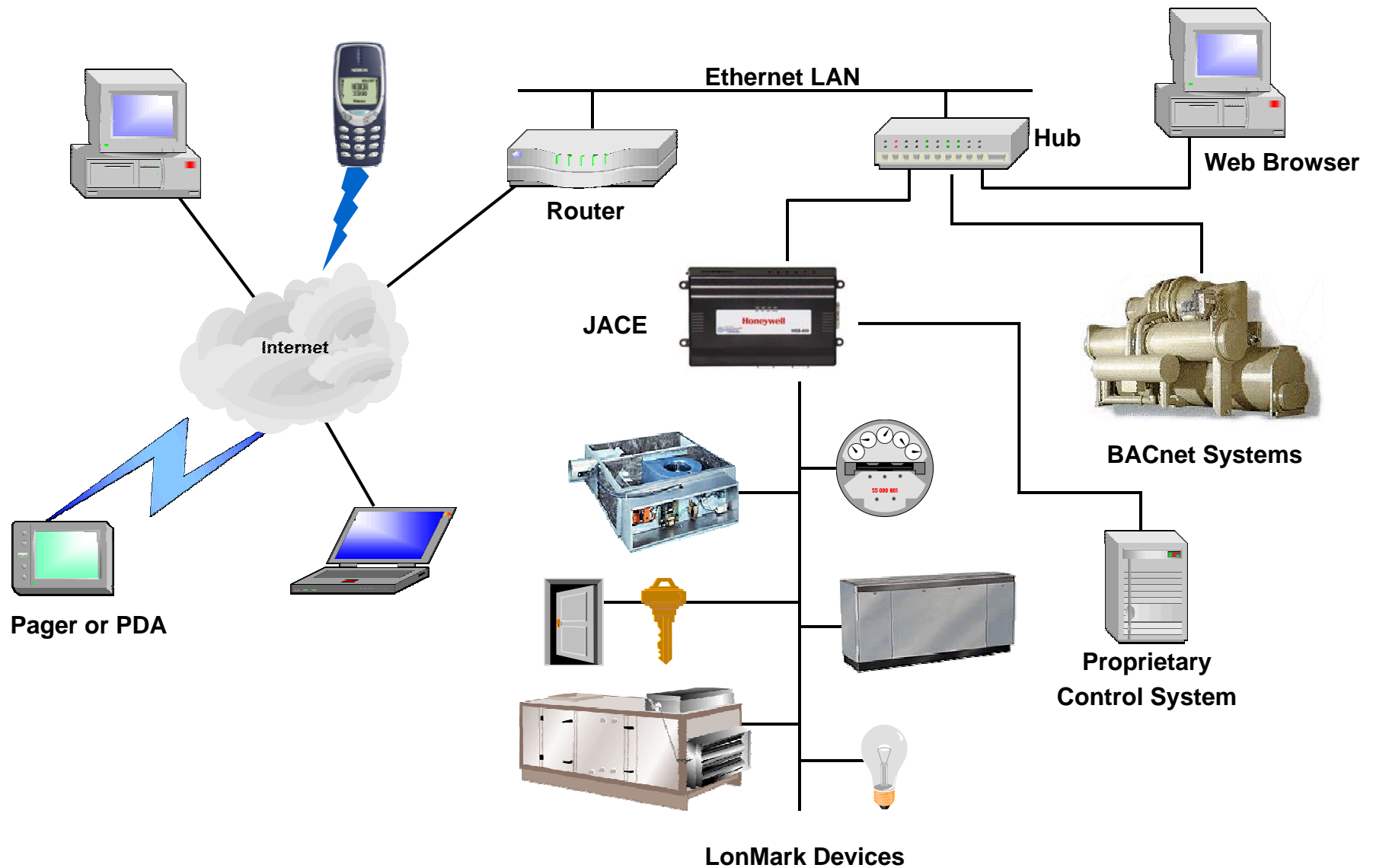

R2 or AX????

- **R2 – Introduced in 1999**
- **AX – Introduced in 2006**

- **When working with a customer who has an existing Niagara installation, you need to determine which platform is installed.**

- **There is an interface from R2 to AX called oBIX (Open Building Information Exchange).**

WEBs Security

Honeywell

A Historical Perspective

- **Integrated Automation and Security Systems**
 - **Were historically expensive**
 - **Weren't applicable to small buildings**
 - **Required complex installation and programming**
 - **Didn't integrate into third party systems**
 - **Required a PC for the user interface**
 - **Required extensive knowledge to use and maintain**

Honeywell WEBS^{AX} Security

Honeywell

- **Web enabled Access Control & Intrusion Detection**
 - **Designed and built on the Niagara^{AX} Framework**
 - **Real-time access control**
 - **Expands the WEBS^{AX} system into advanced Building Automation**
 - ◆ Seamless Integration to HVAC, Lighting, Energy Management
 - **Utilizes Weigand protocol for peripherals**
 - ◆ Enables usage of third party devices
 - **Two versions available**
 - ◆ Stand alone controllers
 - ◆ Panelized versions with lockable panels

Accessible Via a Browser from Anywhere in the World

Enterprise Security Architecture

Honeywell

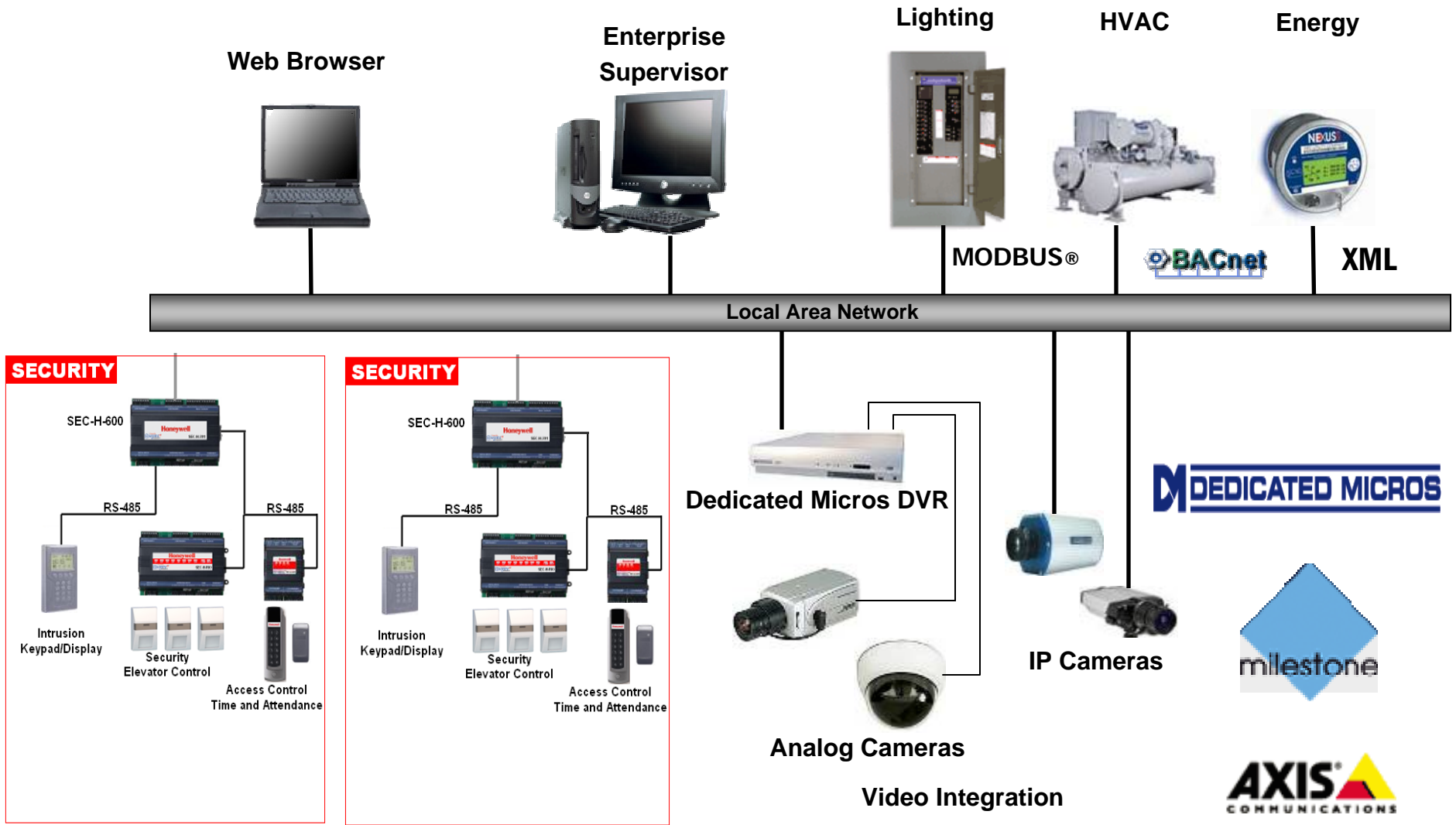

Access Control – Multi-JACE Solution

Combo Architecture

Tridium's Security Solution

- No server PC required
- No thick client software, access via browser
- Integrated BAS
- Security / HVAC from single controller
- Enterprise integration via XML, oBIX

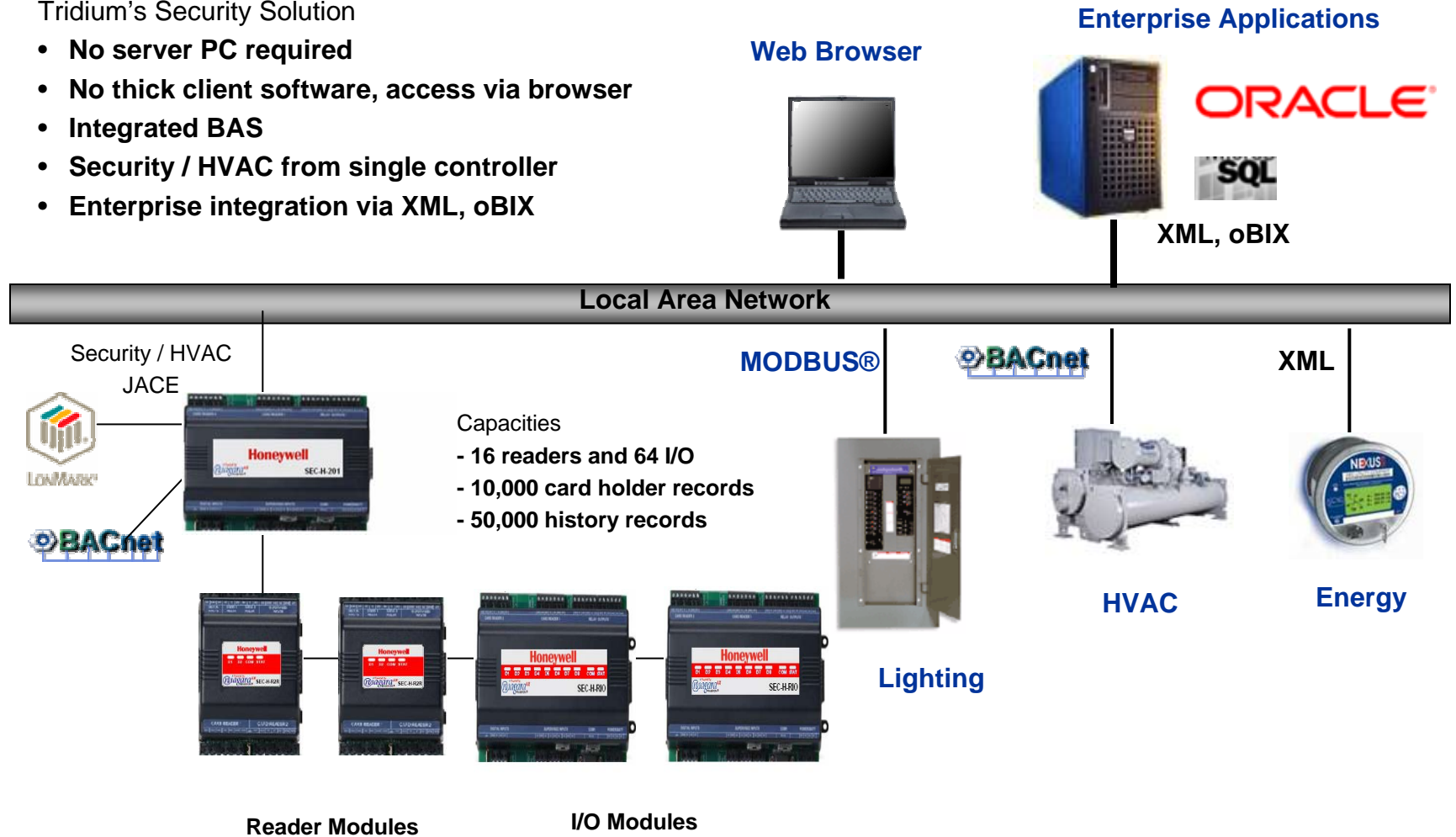

Security / HVAC Combo JACE

- **Cost Effective Solution for Integrated Security / BAS**
 - Small to medium sized facilities (< 100,000 sq ft)
 - Up to 16 card readers
- **Utilize Security JACE 6 Platform**
 - Access control provided through security application
 - BAS available through LON / BACnet / Modbus / etc.
 - BAS station development through Workbench tool
- **Product Structure**
 - Base controller with add-on driver option packs
 - Option packs include primary and secondary drivers
- **Tridium to Provide Engineering Guidelines**
 - Typical system capacities / station resource usage
 - Workbench guidelines of DOs and DONTs to protect existing security application and overall JACE performance

Combo JACE – Base Platform

- **Combined JACE - Base Platform Capacities**
 - Security JACE 6 hardware
 - 15 security modules
 - Max 16 card readers
 - Max 4 intrusion keypads
 - 10,000 personnel records
 - 50,000 history records
 - Drivers included: BACnet IP, FOX, and oBIX
 - Can add max 1 driver option pack to base platform

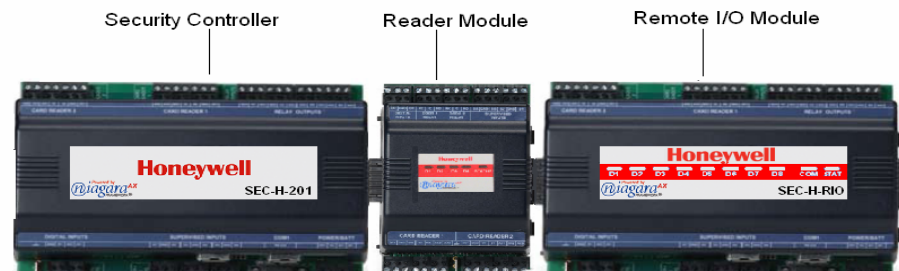

Multi-Protocol Drivers

- **Driver Option Pack 1 – BACnet MSTP Focused**
 - BACnet MSTP: 60 devices, 2000 points
 - LON: 5 devices, 100 points
 - Modbus TCP: 5 devices, 100 points
 - Modbus RTU: 5 devices, 100 points
 - SNMP: 5 devices, 100 points
- **Driver Option Pack 2 – LON Focused**
 - LON: 60 devices, 2000 points
 - BACnet MSTP: 5 devices, 100 points
 - Modbus TCP: 5 devices, 100 points
 - Modbus RTU: 5 devices, 100 points
 - SNMP: 5 devices, 100 points
- **Communication Option Cards Sold Separately**



Thank You

