

# NMX24-MFT-T N4, NMX24-MFT-T N4H

NEMA 4X, Proportional Control, Non-Spring Return, Direct Coupled, 24V, Multi-Function Technology®



Technical Data	NMX24-MFT-T N4, NMX24-MFT-T N4H
Power supply	24 VAC ± 20% 50/60 Hz 24 VDC ± 10%
Power consumption	3.5 W (1.3 W) / heater 24 W
Transformer sizing	6 VA (Class 2 power source) / heater 21 VA
Electrical connection	screw terminal (for 26 to 14 GA wire [heater 15 GA wire]) 1/2" conduit connector
Overload protection	electronic throughout 0 to 95° rotation
Operating range Y	2 to 10 VDC, 4 to 20 mA (default) variable (VDC, PWM, floating point, on/off)
Input impedance	100 kΩ (0.1 mA), 500 Ω 1500 Ω (PWM, floating point, on/off)
Feedback output U	2 to 10 VDC, 0.5 mA max, VDC variable
Angle of rotation	max. 95°, adjustable with mechanical stop electronically variable
Torque	70 in-lb [8 Nm]
Direction of rotation	reversible with  switch
Position indication	pointer
Manual override	external push button
Running time	150 seconds (default) variable (45 to 170 seconds)
Humidity	5 to 95% RH non condensing (EN 60730-1)
Ambient temperature	-22°F to 122°F [-30°C to 50°C]
Storage temperature	-40°F to 176°F [-40°C to 80°C]
Housing	UL type 4X, NEMA 4X, IP 66/67
Housing material	UL94-5VA
Agency listings†	cULus acc. to UL 60730-1A/-2-14, CAN/CSA E60730-1, CSA C22.2 No. 24-93, CE acc. to 89/336/EEC
Noise level	<45dB(A)
Servicing	maintenance free
Quality standard	ISO 9001
Weight	3.2 lbs [1.45 kg] 3.6 lbs [1.6 kg] with heater

†Rated Impulse Voltage 800V, Type of action 1, Control Pollution Degree 3.

Torque min. 70 in-lb for control of damper surfaces up to 16 sq ft.

## Application

For proportional modulation of dampers in HVAC systems. Actuator sizing should be done in accordance with the damper manufacturer's specifications.

The actuator is mounted directly to a damper shaft up to 1.05" in diameter by means of its universal clamp.

The default parameters for 2 to 10 VDC applications of the ...MFT actuator are assigned during manufacturing. If necessary, custom versions of the actuators can be ordered. The parameters can be changed by two means: pre-set and custom configurations from Belimo or on-site configurations using the Belimo PC-Tool software.

## Operation

The actuator is not provided with and does not require any limit switches, but is electronically protected against overload. The anti-rotation strap supplied with the actuator will prevent lateral movement.

The NMB(X)24-MFT-T N4 provides 95° of rotation and a visual indicator indicates position of the actuator. When reaching the damper or actuator end position, the actuator automatically stops. The gears can be manually disengaged with a button on the actuator cover.

The NMB(X)24-MFT-T N actuators use a brushless DC motor, which is controlled by an Application Specific Integrated Circuit (ASIC). The ASIC monitors and controls the actuator's rotation and provides a digital rotation sensing (DRS) function to prevent damage to the actuator in a stall condition. Power consumption is reduced in holding mode.

Add-on auxiliary switches or feedback potentiometers are easily fastened directly onto the actuator body for signaling and switching functions.

## Dimensions (Inches [mm])

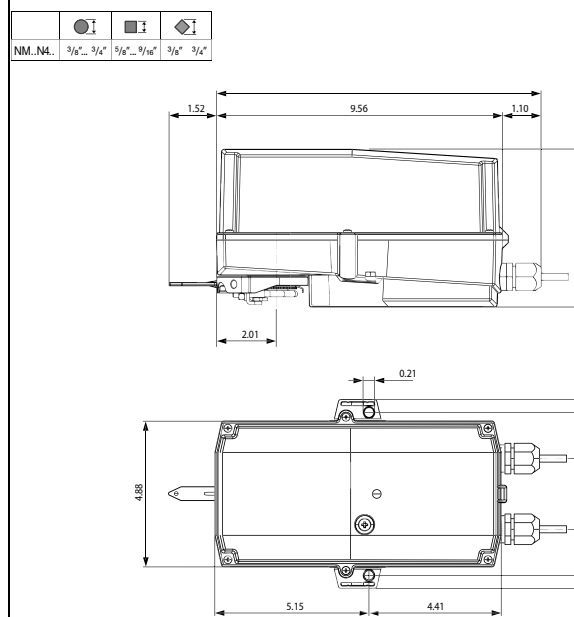

M40024 - 05/10 - Subject to change. © Belimo Aircontrols (USA), Inc.

**Accessories**

S1A, S2A	Auxiliary Switch (es)
P...A	Feedback Potentiometers
SGA24	Min positioners for surface mounting
SGF24	Min positioners for flush panel mounting
ADS-100	Analog to Digital Switch
ZG-R01	Resistor for 4 to 20 mA Conversion
NSV24 US	Battery Back-Up Module
ZG-X40	Transformer

**Typical Specification**

Proportional control damper actuators shall be electronic direct-coupled type, which require no crank arm and linkage and be capable of direct mounting to a shaft up to 3/4" diameter. Actuators must provide proportional damper control in response to a 2 to 10 VDC or, with the addition of a 500 Ω resistor, a 4 to 20 mA control input from an electronic controller or positioner. Actuators shall have brushless DC motor technology and be protected from overload at all angles of rotation. Actuators shall have reversing switch and manual override on the cover. Run time shall be constant and independent of torque. Actuators shall be cULus listed, have a 5-year warranty, and be manufactured under ISO 9001 International Quality Control Standards. Actuators shall be as manufactured by Belimo.

**Wiring Diagrams**

**INSTALLATION NOTES**

- 1 Provide overload protection and disconnect as required.
- 2 **CAUTION Equipment damage!** Actuators may be connected in parallel if not mechanically mounted to the same shaft. Power consumption and input impedance must be observed.
- 3 Actuators may also be powered by 24 VDC.
- 4 Position feedback cannot be used with Triac sink controller. The actuator internal common reference is not compatible.
- 5 Control signal may be pulsed from either the Hot (source) or the Common (sink) 24 VAC line.
- 8 Contact closures A & B also can be triacs.
- 9 For triac sink the common connection from the actuator must be connected to the hot connection of the controller.

**APPLICATION NOTES**

- ◆ The ZG-R01 500 Ω resistor may be used.

**WARNING Live Electrical Components!**

During installation, testing, servicing and troubleshooting of this product, it may be necessary to work with live electrical components. Have a qualified licensed electrician or other individual who has been properly trained in handling live electrical components perform these tasks. Failure to follow all electrical safety precautions when exposed to live electrical components could result in death or serious injury.

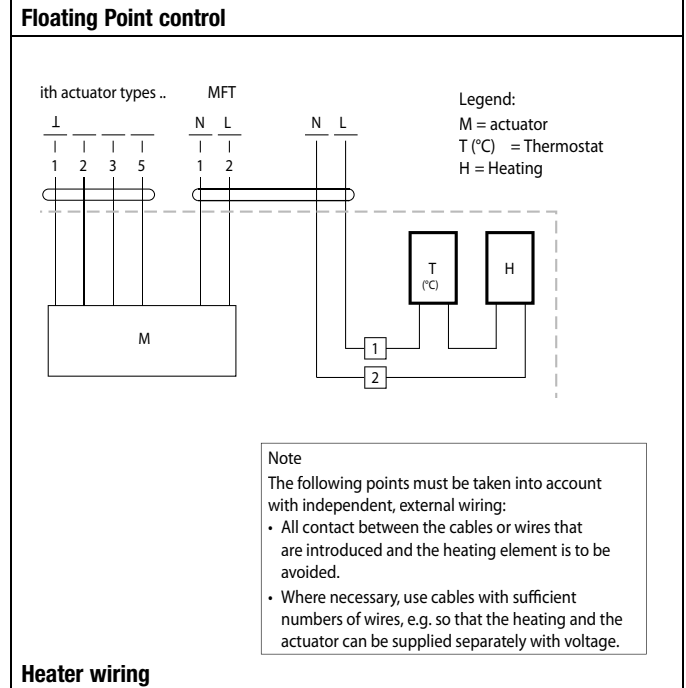
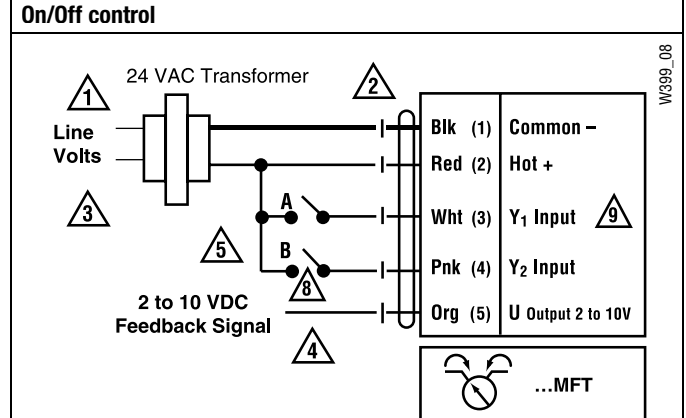
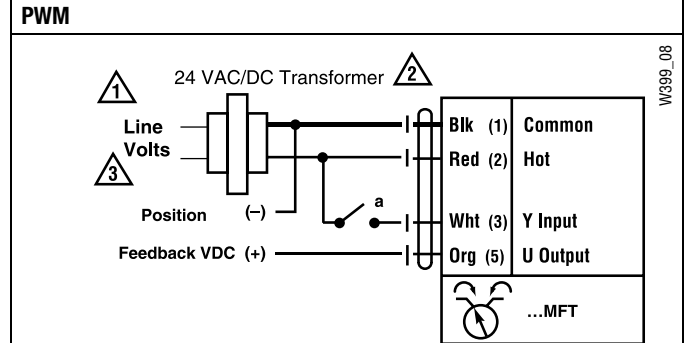
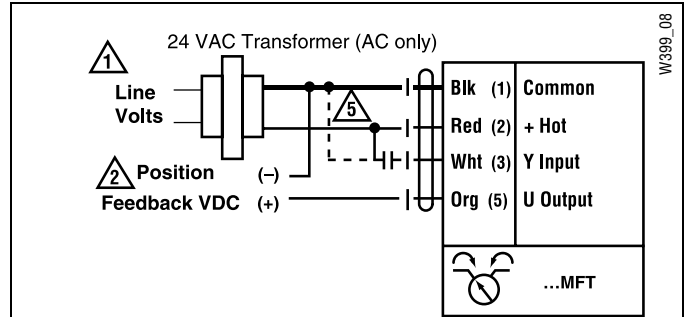
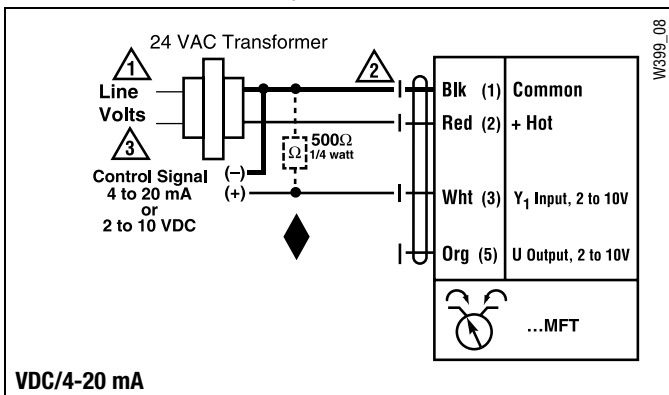

M40024 - 05/10 - Subject to change. © Belimo Aircontrols (USA), Inc.

W399\_08

W399\_08

W399\_08

W399\_08