

MAXITROL[®]  **company**

210 & 220 series gas pressure regulators for industrial applications



210 Series

Dimensions and Spring Ranges

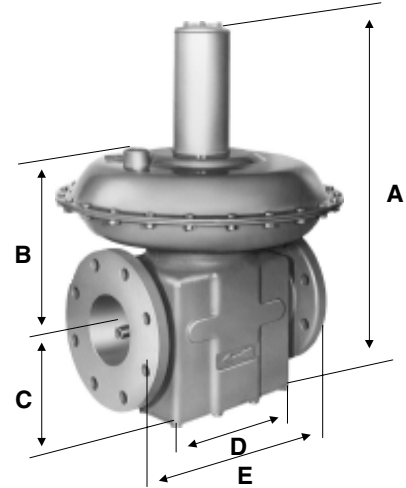
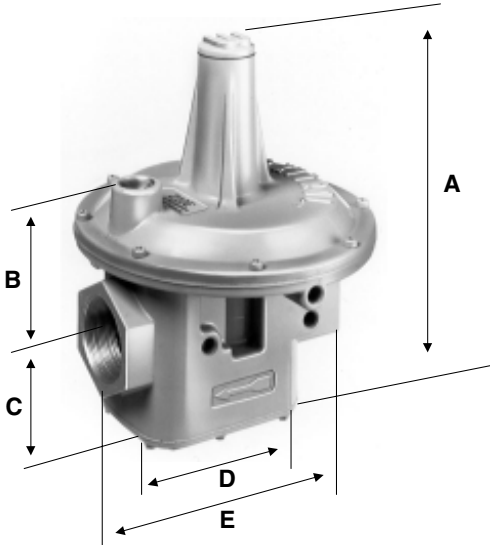

DIMENSIONS

Model and Illustration Number		Pipe Size	Diameter	Dimensions				
				A	B	C	D	E
210D	1	1x1 1 1/4 x 1 1/4 1 1/2 x 1 1/2	7 in. 178 mm	8 7/8 in. 225 mm	3 5/8 in. 92 mm	27/16 in. 62 mm	3 7/8 in. 98 mm	5 1/2 in. 140 mm
210E	1	1 1/2 x 1 1/2 2 x 2	9 1/8 in. 232 mm	11 1/4 in. 286 mm	4 5/16 in. 110 mm	2 5/16 in. 59 mm	5 3/4 in. 146 mm	7 5/8 in. 194 mm
210G	1	2 1/2 x 2 1/2 3 x 3	13 7/16 in. 341 mm	16 1/16 in. 408 mm	6 1/8 in. 156 mm	4 1/4 in. 105 mm	8 1/8 in. 206 mm	10 3/8 in. 265 mm
210J	1	4 x 4	18 in. 457 mm	24 3/16 in. 615 mm	10 7/16 in. 265 mm	5 7/16 in. 138 mm	9 1/2 in. 241 mm	13 3/4 in. 349 mm

SPRING RANGE SELECTION CHART (inches w.c.)

For additional information see *Bulletin MP2012*

Model Number	Standard* Plated	Brown	Orange	Green	Cd Plt	Pink	Violet	Blue	Red	Yellow	Black
210D	3 to 6	1 to 3.5	4 to 8	5 to 15	2 to 5	3 to 8	4 to 12	5 to 12	10 to 22	15 to 30	20 to 42
210E	3 to 6	3 to 6	4 to 8	5 to 15	2 to 5	3 to 8	4 to 12	5 to 12	10 to 22	15 to 30	20 to 42
210G	3 to 6	3 to 6	4 to 8	5 to 15	2 to 5	3 to 8	4 to 12	5 to 12	10 to 22	15 to 30	20 to 42
210J	3 to 6	—	—	—	—	3 to 8	4 to 12	5 to 12	10 to 22	15 to 30	20 to 42

*Factory set at 4.0 w.c.

210 series spring loaded models

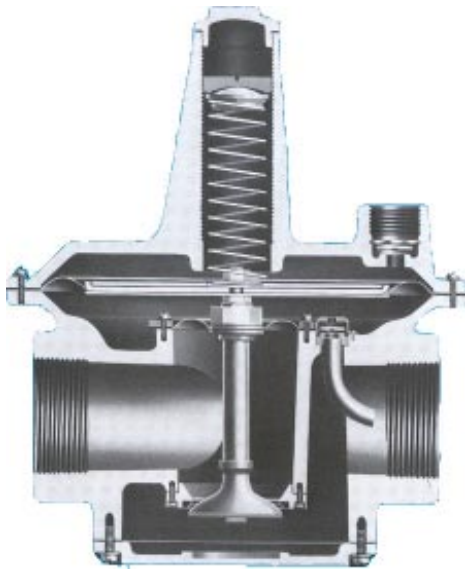

CAPACITIES to 50,000 CFH
EMERGENCY EXPOSURE 25 psi
INLET PRESSURES to 10 psi
OUTLET PRESSURE 1.0" w.c. to 42" w.c.

The 210 series is a lock-up type regulator and complies with codes using the specification.

The 210 series has been designed for maximum control functions in an easy-to-use package. For gas-fired boilers, steam generators, industrial furnaces, ovens and similar high demand equipment.

Balanced valve design eliminates the inlet pressure effect acting on the valve. Regulating stability is improved and hunting tendencies reduced by the use of dampening mechanisms in both the breather outlet and sensing tube. You get precise regulation over a broad range of pressures and flow rates with a Maxitrol 210, including "zero governor" application.

Housings of the 210D, E & G models are of high-strength aluminum alloy. The housings are reinforced with webs for maximum strength. The 210J models are of cast iron and steel construction with 125 pound flange connections. . . . Internal parts are cast or machined from corrosion resistant metals or are electro plated. Diaphragms are of the finest quality synthetic coated fabrics. The regulators are painted providing a protective coating if used out-of-doors.

210 series industrial regulators are intended for use with all fuel gases. Ambient temperature limits are -40°F to 200°F. Maximum emergency exposure pressure is 25 psi. At this pressure, the regulator will suffer no internal damage but it may not provide accurate regulation.

The regulator should be mounted in an upright position in a horizontal pipe run. Gas flow must be oriented to arrow on bottom casting. When selecting

for pipe size, make sure regulator is not more than one size smaller or one size larger than manifold pipe size.

For "zero governor" applications, a counterspring is mounted beneath the valve. A maximum inlet pressure of 5 psi is recommended. Outlet pressure may be adjusted from -1.0" w.c. to +1.5" w.c. The Maxitrol 210 is designed to operate as a zero governor in the normal upright position.

SENSING TAPS AVAILABLE

Tap locations are available for downstream sensing, cross connections, and differential control. Four convenient locations can be tapped and plugged for measuring pressure.

Vertical vent tapped - 3/8" NPT on 210D, 3/4" NPT on 210E, G & J

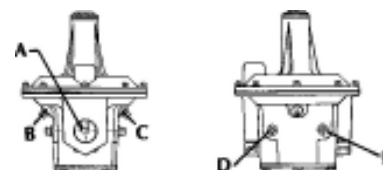

- A. Internal sensing #7 — furnished as standard.**
- B. Remote sensing tap #5.**
- C. Remote sensing tap #6.**
- D. Outlet pressure tap #2. #1 on side opposite.**
- E. Inlet pressure tap #4. #3 on side opposite.**

Capacities for spring loaded models

CUBIC FEET PER HOUR (0.64 sp gr gas)

Inlet Pressure									
	2	4	6	9	12	16	20	24	28

210D 1"

8.0" w.c.	2,400	1,900	1,300						
0.5 psi	3,400	3,100	2,700	2,200					
0.75 psi	3,500	4,000	3,800	3,400	2,900	2,200			
1.0 psi	3,500	4,000	4,500	4,300	3,900	3,400	2,700	1,900	
1.5 psi	3,500	4,000	4,500	4,800	4,800	5,000	4,600	4,100	3,600
2.0 psi	3,500	4,000	4,500	4,800	4,800	5,000	5,000	5,000	5,000
3.0 psi	3,500	4,000	4,500	4,800	4,800	5,000	5,000	5,000	5,000
5.0 psi	3,500	4,000	4,500	4,800	4,800	5,000	5,000	5,000	5,000
7.5 psi	3,500	4,000	4,500	4,800	4,800	5,000	5,000	5,000	5,000
10.0 psi	3,500	4,000	4,500	4,800	4,800	5,000	5,000	5,000	5,000

210D 1-1/4"

8.0" w.c.	3,000	2,400	1,700						
0.5 psi	4,000	3,905	3,400	2,700					
0.75 psi	4,000	5,000	4,700	4,200	3,700	2,700			
1.0 psi	4,000	5,000	5,000	5,300	4,900	4,200	3,400	2,400	
1.5 psi	4,000	5,000	5,000	6,000	6,000	6,000	5,700	5,200	4,600
2.0 psi	4,000	5,000	5,000	6,000	6,000	6,000	6,500	6,500	6,500
3.0 psi	4,000	5,000	5,000	6,000	6,000	6,000	6,500	6,500	6,500
5.0 psi	4,000	5,000	5,000	6,000	6,000	6,000	6,500	6,500	6,500
7.5 psi	4,000	5,000	5,000	6,000	6,000	6,000	6,500	6,500	6,500
10.0 psi	4,000	5,000	5,000	6,000	6,000	6,000	6,500	6,500	6,500

210D 1-1/2"

8.0" w.c.	3,100	2,500	1,800						
0.5 psi	4,000	4,000	3,600	2,800					
0.75 psi	4,000	5,000	5,000	4,400	3,800	2,800			
1.0 psi	4,000	5,000	5,000	5,600	5,100	4,400	3,600	2,500	
1.5 psi	4,000	5,000	5,000	6,000	6,000	6,500	6,000	5,400	4,800
2.0 psi	4,000	5,000	5,000	6,000	6,000	6,500	6,500	6,500	6,500
3.0 psi	4,000	5,000	5,000	6,000	6,000	6,500	6,500	6,500	6,500
5.0 psi	4,000	5,000	5,000	6,000	6,000	6,500	6,500	6,500	6,500
7.5 psi	4,000	5,000	5,000	6,000	6,000	6,500	6,500	6,500	6,500
10.0 psi	4,000	5,000	5,000	6,000	6,000	6,500	6,500	6,500	6,500

210E 1-1/2"

8.0" w.c.	4,450	3,650	2,550						
0.5 psi	6,300	5,750	5,150	4,050					
0.75 psi	7,000	7,500	7,050	6,300	5,450	4,050			
1.0 psi	7,000	8,800	8,500	7,950	7,250	6,300	5,150	3,650	
1.5 psi	7,000	8,800	8,800	10,450	9,950	9,250	8,550	7,700	6,800
2.0 psi	7,000	8,800	8,800	10,500	10,500	10,500	10,500	10,250	9,600
3.0 psi	7,000	8,800	8,800	10,500	10,500	10,500	10,500	10,500	10,500
5.0 psi	7,000	8,800	8,800	10,500	10,500	10,500	10,500	10,250	10,500
7.5 psi	7,000	8,800	8,800	10,500	10,500	10,500	10,500	10,250	10,500
10.0 psi	7,000	8,800	8,800	10,500	10,500	10,500	10,500	10,250	10,500

CUBIC FEET PER HOUR (0.64 sp gr gas)

Inlet Pressure									
	2	4	6	9	12	16	20	24	28

210E 2"

8.0" w.c.	5,150	4,200	2,950						
0.5 psi	7,250	6,650	5,950	4,700					
0.75 psi	8,000	8,650	8,150	7,250	6,300	4,700			
1.0 psi	8,000	10,000	9,850	9,150	8,400	7,250	5,950	4,200	
1.5 psi	8,000	10,000	10,000	12,000	11,500	10,700	9,850	8,900	7,850
2.0 psi	8,000	10,000	10,000	12,000	12,000	12,000	12,000	11,850	11,000
3.0 psi	8,000	10,000	10,000	12,000	12,000	12,000	12,000	12,000	12,000
5.0 psi	8,000	10,000	10,000	12,000	12,000	12,000	12,000	12,000	12,000
7.5 psi	8,000	10,000	10,000	12,000	12,000	12,000	12,000	12,000	12,000
10.0 psi	8,000	10,000	10,000	12,000	12,000	12,000	12,000	12,000	12,000

210G 2-1/2"

8.0" w.c.	10,400	8,500	6,000						
0.5 psi	14,700	13,410	12,000	9,500					
0.75 psi	16,000	17,500	16,400	14,700	12,750	9,500			
1.0 psi	16,000	20,000	19,900	18,500	16,950	14,700	12,000	8,500	
1.5 psi	16,000	20,000	20,000	24,000	23,250	21,600	19,900	18,000	15,850
2.0 psi	16,000	20,000	20,000	24,000	24,000	24,000	24,000	24,000	22,450
3.0 psi	16,000	20,000	20,000	24,000	24,000	24,000	24,000	24,000	24,000
5.0 psi	16,000	20,000	20,000	24,000	24,000	24,000	24,000	24,000	24,000
7.5 psi	16,000	20,000	20,000	24,000	24,000	24,000	24,000	24,000	24,000
10.0 psi	16,000	20,000	20,000	24,000	24,000	24,000	24,000	24,000	24,000

210G 3"

8.0" w.c.	11,500	9,400	6,600						
0.5 psi	16,000	14,800	13,200	10,450					
0.75 psi	16,000	19,300	18,100	16,200	14,000	10,450			
1.0 psi	16,000	20,000	20,000	20,350	18,700	16,200	13,200	9,350	
1.5 psi	16,000	20,000	20,000	24,000	24,000	23,800	21,900	19,800	17,450
2.0 psi	16,000	20,000	20,000	24,000	24,000	27,000	27,000	26,400	24,700
3.0 psi	16,000	20,000	20,000	24,000	24,000	27,000	27,000	27,000	27,000
5.0 psi	16,000	20,000	20,000	24,000	24,000	27,000	27,000	27,000	27,000
7.5 psi	16,000	20,000	20,000	24,000	24,000	27,000	27,000	27,000	27,000
10.0 psi	16,000	20,000	20,000	24,000	24,000	27,000	27,000	27,000	27,000

210J 4"

8.0" w.c.	20,800	17,000	12,000						
0.5 psi	29,500	27,000	24,000	19,000					
0.75 psi	32,000	35,000	33,000	29,420	25,500	19,000			
1.0 psi	32,000	40,000	40,000	37,000	34,000	29,420	24,000	17,000	
1.5 psi	32,000	40,000	40,000	48,000	47,000	43,350	39,700	36,000	31,800
2.0 psi	32,000	40,000	40,000	48,000	48,000	50,000	50,000	48,000	45,000
3.0 psi	32,000	40,000	40,000	48,000	48,000	50,000	50,000	50,000	50,000
5.0 psi	32,000	40,000	40,000	48,000	48,000	50,000	50,000	50,000	50,000
7.5 psi	32,000	40,000	40,000	48,000	48,000	50,000	50,000	50,000	50,000
10.0 psi	32,000	40,000	40,000	48,000	48,000	50,000	50,000	50,000	50,000

Pressure Drop

SPRING LOADED DESIGN

Flow Rate CFH	Values expressed in inches w.c.							
	210D			210E		210G		210J
	1"	1 1/4"	1 1/2"	1 1/2"	2"	2 1/2"	3"	4"
500	0.23	0.15	0.14					
1,000	0.92	0.59	0.54	0.27	0.20	0.05	0.04	0.01
1,500	2.08	1.33	1.22					
2,000	3.70	2.37	2.16	1.09	0.82	0.20	0.17	0.05
2,500	5.78	3.70	3.38					
3,000	8.32	5.33	4.87	2.46	1.84	0.45	0.37	0.12
3,500	11.33	7.25	6.62					
4,000	14.79	9.47	8.65	4.37	3.28	0.80	0.66	0.21
4,500	18.72	11.98	10.95					
5,000	23.11	14.79	13.52	6.82	5.12	1.25	1.03	0.34
5,500	27.97	17.90	16.35					
6,000	33.28	21.30	19.46	9.82	7.37	1.80	1.48	0.49
6,500		25.00	22.84					
7,000		28.99	26.49	13.36	10.05	2.45	2.02	0.66
7,500			30.41					
8,000				17.45	13.10	3.20	2.64	0.87
8,500								
9,000				22.10	16.60	4.05	3.35	1.10
9,500								
10,000				27.30	20.50	5.00	4.15	1.35
11,000				33.00	24.80	6.05	5.00	
12,000				39.30	29.50	7.20	5.95	1.95
13,000					34.60	8.50	7.00	
14,000					40.15	9.85	8.10	2.68
15,000						11.30	9.30	
16,000						12.85	10.60	3.47
17,000						14.50	11.95	
18,000						16.25	13.40	4.40
19,000						18.10	14.90	
20,000						20.05	16.50	5.42
22,000						24.25	20.00	6.56
24,000						28.85	23.80	7.81
26,000						33.85	27.90	9.06
28,000						39.25	32.40	10.62
30,000							37.20	12.41
32,000								13.90
34,000								15.69
36,000								17.60
38,000								19.60
40,000								21.70
45,000								27.40
50,000								33.80
55,000								41.00

NOTE: The maximum capacities for the different models listed on the capacity chart and represented by the heavy line on the pressure drop table are values at which these controls have been certified by the C.G.A. (except for the 210J).

220 series pilot loaded models



NOT C.G.A. CERTIFIED

CAPACITIES to 50,000 CFH
EMERGENCY EXPOSURE 25 psi
INLET PRESSURES to 10 psi
OUTLET PRESSURE 1 psi to 5 psi

The 220 series, utilizing a servo-operated design rather than the more conventional spring-loaded design, delivers higher outlet pressure than the spring loaded models.

The main diaphragm on the Maxitrol 220 is loaded with gas pressure rather than with a spring. This gas pressure is precisely controlled by a small pilot regulator in the upper housing. When the regulated outlet pressure of the pilot regulator is changed, by spring adjustment, the outlet pressure of the main regulator will change proportionately.

Outlet pressure adjustments are readily made by first removing the hood of the Maxitrol 220. Then remove the cap atop the pilot regulator, which exposes the adjusting screw, and adjust to desired pressure.

Three positions can be tapped and plugged for making inlet or outlet pressure readings. The fourth position is used to supply inlet pressure to the pilot regulator. Remote sensing is also available.

220 series industrial regulators are intended for use with all fuel gases.

The regulator will perform most accurately when mounted in an upright position in a horizontal pipe run. Gas flow must be oriented to arrow on regulator. When selecting for pipe size, make sure regulator is not more than one size larger or smaller than manifold pipe size.

Single vent, equipped with model 12A06 vent limiting orifice, is located in upper housing.

Ambient temperature limits are -40°F to 200°F. Maximum emergency exposure pressure is 25 psi. At this pressure the regulator will suffer no internal damage but it may not provide accurate regulation.

Two outlet pressure adjustment springs are available.

R325C10-1022 (K spring) **1 psi to 3 psi**
R325C10-1530 (L spring) **2 psi to 5 psi**

Pressure drop and dimensions

PILOT LOADED DESIGN

Flow Rate CFH	Values expressed in inches w.c.								
	210D			210E		210G		210J	
	1"	1 1/4"	1 1/2"	1 1/2"	2"	2 1/2"	3"	4"	
1,000	1.90	1.70	1.70						
2,000	4.93	3.10	2.90	1.90	1.90				
3,000	11.10	7.42	5.40	2.90	2.40				
4,000	19.70	13.20	11.10	4.93	4.00	2.00	1.90	1.70	
5,000	30.80	20.70	17.40	7.70	6.25	2.20	2.10	1.70	
6,000	44.20	29.70	25.00	11.10	9.00	2.60	2.30	1.70	
7,000		40.60	34.00	15.10	12.25	3.00	2.60	1.70	
8,000			44.50	19.70	16.00	4.00	3.00	1.80	
9,000				24.90	20.25	5.00	3.80	1.90	
10,000				30.80	25.00	6.22	4.60	2.10	
12,000				44.20	36.00	9.00	6.80	2.40	
14,000						12.20	9.30	2.80	
16,000						16.00	12.10	3.40	
18,000						20.20	15.30	4.40	
20,000						25.00	18.90	5.40	
25,000						40.60	30.70	8.90	
30,000							42.50	12.40	
35,000								17.05	
40,000								21.70	
45,000								27.40	
50,000								33.80	
55,000								41.00	

NOTE: Do not exceed 36" pressure drop when determining acceptable capacities at which these controls may be used. Under some conditions these limits may be surpassed, but only after consultation with Maxitrol Company. (NOT C.G.A. CERTIFIED)

DIMENSIONS

Model	A	B	C
220D	10-3/16"	7"	6"
220E	11-1/4"	9-1/8"	7-5/8"
220G	14-3/4"	13-1/2"	10-3/8"
220J	20-1/2"	18"	13-7/8"

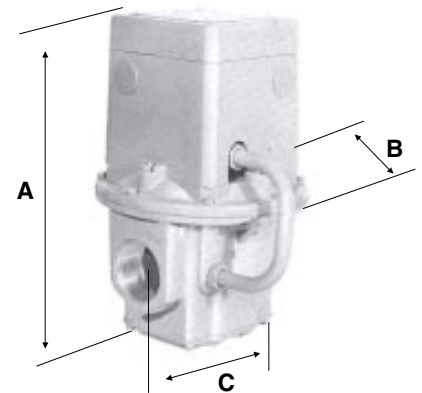
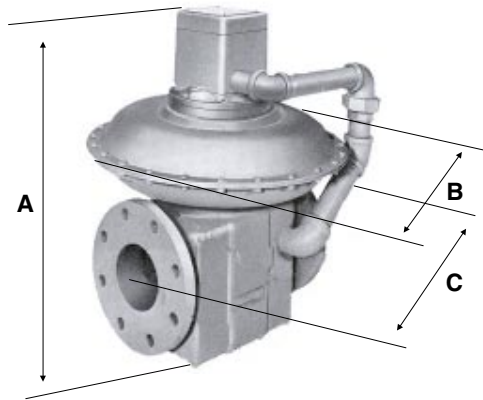

A copyrighted publication of

MAXITROL  **company**

www.maxitrol.com

Maxitrol Company
23555 Telegraph Rd., P.O. Box 2230
Southfield, MI 48037-2230 U.S.A.
248.356.1400 • Fax 248.356.0829



European Representatives
Warnstedter Strasse 3 06502 Thale, Germany
49.3947.400.0 • Fax 49.3947.400.200
Industriestrasse 1 48308 Senden, Germany
49.2597.9632.0 • Fax 49.2597.9632.99

