

T600MSx-3 Multi-Stage Thermostat

Installation Instructions

T600MSN-3, T600MSP-3

Part No. 24-9890-617, Rev. —
Issued September 18, 2006

Applications

The T600MSN-3 non-programmable and T600MSP-3 programmable thermostats are specifically designed for control of multi-stage commercial heating and cooling equipment.

IMPORTANT: The T600MSx-3 Thermostat is intended to provide an input to equipment under normal operating conditions. Where failure or malfunction of the thermostat could lead to personal injury or property damage to the controlled equipment or other property, additional precautions must be designed into the control system. Incorporate and maintain other devices such as supervisory or alarm systems or safety or limit controls intended to warn of or protect against failure or malfunction of the thermostat.

North American Emissions Compliance

United States

This equipment has been tested and found to comply with the limits for a Class A digital device pursuant to Part 15 of the FCC Rules. These limits are designed to provide reasonable protection against harmful interference when this equipment is operated in a commercial environment. This equipment generates, uses, and can radiate radio frequency energy and, if not installed and used in accordance with the instruction manual, may cause harmful interference to radio communications. Operation of this equipment in a residential area is likely to cause harmful interference, in which case the user will be required to correct the interference at his/her own expense.

Canada

This Class (A) digital apparatus meets all the requirements of the Canadian Interference-Causing Equipment Regulations.

Cet appareil numérique de la Classe (A) respecte toutes les exigences du Règlement sur le matériel brouilleur du Canada.

Installation

Location Considerations

Locate the T600MSx-3 thermostat:

- on a partitioning wall, approximately 5 ft (1.5 m) above the floor in a location of average temperature
- away from direct sunlight, radiant heat, outside walls, behind doors, air discharge grills, stairwells, or outside doors
- away from steam or water pipes, warm air stacks, unconditioned areas (not heated or cooled), or sources of electrical interference

Note: Allow for vertical air circulation to the T600MSx-3 thermostat.

To install the thermostat:

1. Use a Phillips-head screwdriver to remove the security screw on the bottom of the thermostat cover.
2. Pull the bottom edge of the thermostat cover and open the thermostat as illustrated in Figure 1.

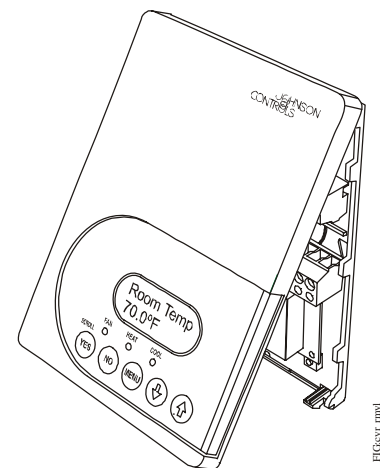

Figure 1: Removing the Thermostat Cover

- Carefully pull the locking tabs on the right side of the thermostat mounting base and unlock the Printed Circuit Board (PCB). Open the PCB to the left as illustrated in Figure 2.

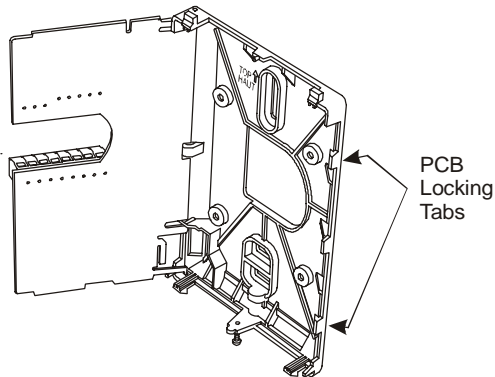

Figure 2: Opening the Thermostat PCB

- Pull approximately 6 in. (152 mm) of wire from the wall and insert the wire through the hole in the thermostat mounting base.
- Align the thermostat mounting base on the wall and use the base as a template to mark the two mounting hole locations.

Note: Be sure to position the thermostat mounting base so that the arrow on the base points upward to indicate the top of the thermostat.

- Drill a 3/16 in. (5 mm) hole at each of the two marked locations and tap nylon anchors (included with the thermostat) flush to the wall surface.
- Position the thermostat mounting base on the wall and use the two mounting screws (included with the thermostat) to secure the base to the surface as illustrated in Figure 3.

Note: Be careful not to overtighten the mounting screws.

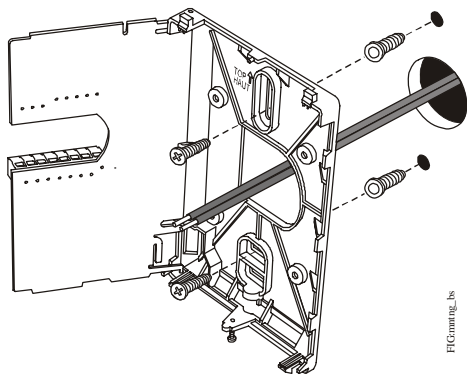

Figure 3: Securing the Thermostat Mounting Base to the Wall

- Swing the PCB back to the right and carefully snap it into the locking tabs on the thermostat mounting base.
- Pull the pull-tabs on each of the connectors and remove the screw terminal blocks as illustrated in Figure 4.

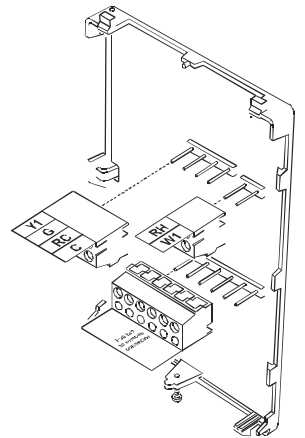

Figure 4: Removing the Screw Terminal Blocks

Wiring

When an existing thermostat is replaced, remove and label the wires to identify the terminal functions. When a T600MSx-3 thermostat is replaced, simply remove the old screw terminal blocks and reinsert them onto the PCB of the replacement thermostat.



CAUTION: Risk of Electric Shock.

Disconnect the power supply before making electrical connections to avoid electric shock.



CAUTION: Risk of Property Damage.

Do not apply power to the system before checking all wiring connections. Short circuited or improperly connected wires may result in permanent damage to the equipment.

IMPORTANT: Make all wiring connections in accordance with local, national, and regional regulations. Do not exceed the electrical ratings of the T600MSx-3 thermostat.

To wire the thermostat:

1. Strip the ends of each wire a 1/4 in. (6 mm) and connect them to the appropriate screw terminals as indicated in Figure 5.
2. Carefully push any excess wire back into the wall. Seal the hole in the wall with fireproof material to prevent drafts from affecting the ambient temperature readings.
3. Reinsert the screw terminal blocks onto the PCB.
4. Reattach the thermostat cover to the mounting base (top side first).

Note: Use a Phillips-head screwdriver to reinstall the security screw on the bottom of the thermostat cover.

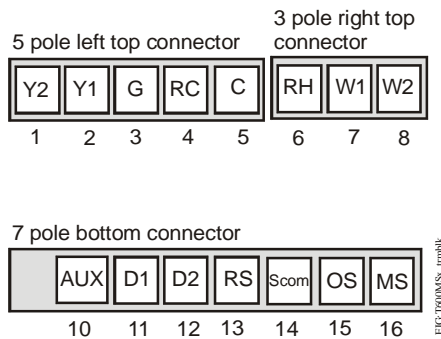

Figure 5: Terminal Blocks

Table 1: Terminal Identification (See Figure 5.)

Number	Label	Function
1	Y2	Energizes on a call for second-stage cooling.
2	Y1	Energizes on a call for first-stage cooling.
3	G	Energizes fan in accordance with selected fan mode.
4	RC	24 VAC from equipment transformer
5	C	24 VAC (Common) from equipment transformer
6	RH	24 VAC for heating stage
7	W1	Energizes on a call for first-stage heating.
8	W2	Energizes on a call for second-stage heating.
10	Aux	Auxiliary output
11	DI1	Configurable Digital Input 1
12	DI2	Configurable Digital Input 2
13	RS	Remote Room Temperature Sensor
14	Scom	Sensor Common
15	OS	Outdoor Air Sensor
16	MS	Not Used

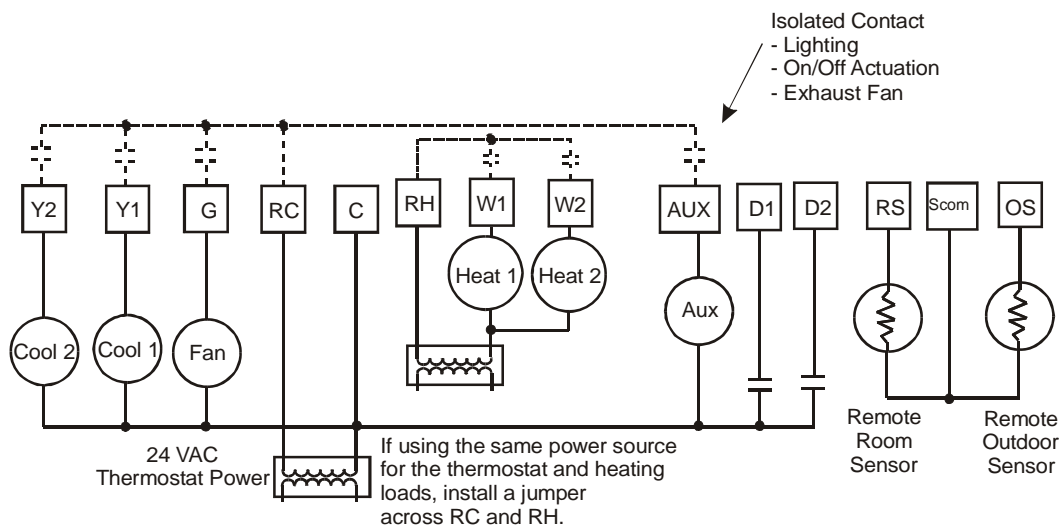

Figure 6: Wiring the T600MSx-3 Thermostats

Setup and Adjustments

Thermostat Operation Overview

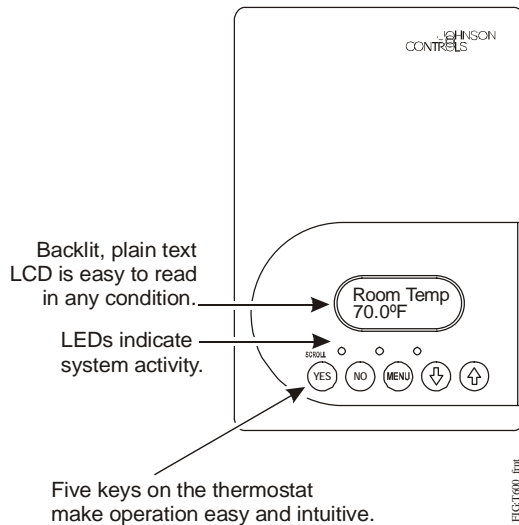

Figure 7: Front Cover of Thermostat

Thermostat User Interface Keys

The T600MSx-3 thermostat user interface consists of five keys on the front cover (as illustrated in Figure 7). The function of each key is as follows:

- Use the **YES/SCROLL** key to:
 - confirm menu selections and to advance to the next menu item
 - stop the Status Display Menu from scrolling and to manually scroll to the next parameter on the menu

Note: When the thermostat is left unattended for 45 seconds, the thermostat display resumes scrolling.

- Use the **NO** key to decline a parameter change and to advance to the next menu item.

- Use the **MENU** key to:
 - access the Main User Menu or exit the menu
 - access the Installer Configuration Menu or to exit the menu (See the *Configuring the T600MSx-3 Thermostat Thermostat* section.)
- Use the **UP/DOWN** arrow keys to change the configuration parameters and to activate a setpoint adjustment.

Backlit Liquid Crystal Display (LCD)

The T600MSx-3 thermostat includes a 2-line, 8-character backlit display. Low-level backlighting is present during normal operation, and it brightens when any user interface key is pressed. The backlight returns to low level when the thermostat is left unattended for 45 seconds.

Light-Emitting Diodes (LEDs)

Three LEDs are included to indicate the fan status, call for heat, or call for cooling:

- The **FAN** LED is on when the fan is on.
- The **HEAT** LED is on when heating is on.
- The **COOL** LED is on when cooling is on.

Programming Overview

There are three menus used to view, program, and configure the T600MSx-3 thermostat:

The **Status Display Menu** is displayed during normal thermostat operation. This menu continuously scrolls through the following parameters:

- Room Temperature
- Day and Time (T600MSP-3)
- System Mode
- Occupancy Status – Occupied/Unoccupied/Override (T600MSP-3)

- Outdoor Temperature – An outdoor air temperature sensor must be connected.
- Applicable Alarms – The backlight lights up as an alarm condition is displayed.

Note: Press the **YES/SCROLL** key to temporarily stop this menu from scrolling.

The **Main User Menu** is used to access and change the basic operating parameters of the thermostat. Access this menu by pressing the **MENU** key during normal thermostat operation.

The **Installer Configuration Menu** is used to set up the thermostat for application-specific operation. To access this menu, press and hold the **MENU** key for approximately 8 seconds.

Configuring the T600MSx-3 Thermostat

The T600MSx-3 thermostat comes from the factory with default settings for all configurable parameters. The default settings are shown in Table 2. To reconfigure the parameters via the thermostat, follow the steps in this section.

1. To access the Installer Configuration Menu, press and hold the **MENU** key for approximately 8 seconds.

2. Once the Installer Configuration Menu begins, press the **NO** key to scroll through the parameters listed in Table 2.
3. When the desired parameter is displayed, use the **YES** key to choose the desired selection option.
4. Press the **YES** key and then the **NO** key to continue scrolling through the parameters.

To exit the Installer Configuration Menu any time, press the **MENU** key, and at the exit prompt, press the **YES** key. To pass over a parameter without changing it, press the **NO** key.

When the thermostat is in the Installer Configuration Menu and left unattended for approximately 8 seconds, the thermostat reverts to the Status Display Menu.

Configuring Inputs DI1 and DI2

When DI1 and DI2 are configured for an alarm condition, an alarm condition is displayed locally when the input is closed. An alarm message is included on the scrolling Status Display Menu and when the message is displayed, the backlight momentarily lights up.

Each input can be configured to the Selection Options included in Table 2.

Table 2: Installer Configuration Menu (Part 1 of 4)

Parameter Appearing on Display	Description and Default	Selection Options
DI1 ¹	Configuration of Digital Input 1. Default: None	<p>(None): No function is associated with an input.</p> <p>(Service): A Service alarm is displayed on the thermostat when the input is energized. This input can be tied into the air conditioning unit control card, which provides an alarm should there be a malfunction.</p> <p>(Filter): A Filter alarm is displayed. This alarm can be connected to a differential pressure switch that monitors a filter.</p> <p>(RemOVR): Temporary occupancy request via a remote input. This override function is controlled by a manual remote occupancy override. When enabled, this condition disables the override capability of the thermostat.</p> <p>(RemNSB): Remote Night Setback (NSB) via a time clock input, an occupancy sensor, or from a voltage-free contact. Contact open = Occupied; contact closed = Unoccupied.</p>
DI2 ¹	Configuration of Digital Input 2. Default: None	<p>(None): No function is associated with an input.</p> <p>(Service): A Service alarm is displayed on the thermostat when the input is energized. This input can be tied into the air conditioning unit control card, which provides an alarm should there be a malfunction.</p> <p>(Filter): A Filter alarm is displayed. This alarm can be connected to a differential pressure switch that monitors a filter.</p> <p>(RemOVR): Temporary occupancy request via a remote input. This override function is controlled by a manual remote occupancy override. When enabled, this condition disables the override capability of the thermostat.</p> <p>(RemNSB): Remote Night Setback (NSB) via a time clock input, an occupancy sensor, or from a voltage-free contact. Contact open = Occupied; contact closed = Unoccupied.</p>

Table 2: Installer Configuration Menu (Part 2 of 4)

Parameter Appearing on Display	Description and Default	Selection Options			
Lockout	Selectable Lockout Levels for limiting end-user keypad interaction. Default: 0	Function	Lockout Level		
			(0)	(1)	(2)
		Occupancy Override	Access	Access	No Access
		Permanent Temperature Setpoints	Access	No Access	No Access
		Temporary Temperature Setpoints	Access	Access	No Access
		System Mode Setting	Access	No Access	No Access
		Fan Mode Setting	Access	No Access	No Access
		Schedule Setting⁴	Access	No Access	No Access
		Clock Setting⁴	Access	Access	Access
Permanent Hold⁴	Access	No Access	No Access		
Pwr del²	Sets the delay time period at thermostat power up, or at each time power is removed and reapplied, before any operation (fan, heating, or cooling) is authorized. Also can be used to sequence the startup of multiple units in one location. Default: 10.0 sec	Range: 10.0 to 120.0 sec			
Frost pr	Provides a minimum heating setpoint of 42.0°F/5.5°C to prevent freezing in the zone controlled by the thermostat. Default: off	(on): Enabled (off): Disabled			
Heat max³	Sets the Occupied and Unoccupied maximum Heating setpoint values. Default: 90.0°F/32.0°C	Range: 40.0°F/4.5°C to 90.0°F/32.0°C			
Cool min³	Sets the Occupied and Unoccupied minimum Cooling setpoint values. Default: 54.0°F/12.0°C	Range: 54.0°F/12.0°C to 100.0°F/37.5°C			
Anticycl	Anti-Short Cycle timer sets the minimum on/off times for heating and cooling stages. Default: 2.0 min	Range: 0.0 to 5.0 min adjustable in 1-minute increments Set the anti-short cycle timer to 0.0 min for equipment that already has its own anti-short cycle timer.			
Heat cph	Sets the maximum number of Heating cycles per hour. Default: 4.0	Range: 3.0 to 8.0 cycles per hour			
Cool cph	Sets the maximum number of Cooling cycles per hour. Default: 4.0	Range: 3.0 or 4.0 cycles per hour			

Table 2: Installer Configuration Menu (Part 3 of 4)

Parameter Appearing on Display	Description and Default	Selection Options
Deadband	Sets the minimum deadband between the heating and cooling setpoints. Default: 2.0F°/1.0C°	Range: 2.0F°/1.0C° to 4.0F°/2.0C° adjustable in 1.0F°/0.5C° increments
Fan cont	Determines how the fan is activated in response to a call for heating. Fan cont applies to W1 & W2 and Fan Mode auto only. Fan cont does not affect fan operation on a call for cooling (Y1 & Y2). Default: on	(off) : The thermostat will not activate the fan in response to a call for heating. The fan is activated by the equipment fan and limit control. (on) : Enables the thermostat to activate the fan in response to a call for heating or cooling.
Fan del	Fan delay extends fan operation after a heating or cooling cycle has ended. Default off	(on) : Extends fan operation by 60 seconds after a heating or cooling cycle has ended. (off) : No extension of fan operation after a heating or cooling cycle has ended. The fan delay is only active when the fan is in the Auto mode.
TOccTime	Sets the duration of the Temporary Occupancy Time (when the thermostat is in the Unoccupied mode) when a Schedule Override Function is enabled using either the Main User Menu or DI1 or DI2 configured as a temporary override remote contact (RemOVR). Sets the effective duration of the Temporary heating or cooling setpoints set using the up/down arrow keys. Default: 3.0 hrs	Range: 0.0 to 12.0 hrs adjustable in 1-hour increments
Cal RS	Sets the desired room air temperature sensor calibration (offset). The offset can be added to or subtracted from the actual displayed room temperature. Default: 0.0F°/0.0C°	Range: -5.0F°/-2.5C° to 5.0F°/2.5C° adjustable in 1.0F°/0.5C° increments
Cal OS	Sets the desired outdoor air temperature sensor calibration (offset). The offset can be added to or subtracted from the actual displayed room temperature. Default: 0.0F°/0.0C°	Range: -5.0F°/-2.5C° to 5.0F°/2.5C° adjustable in 1.0F°/0.5C° increments
H stage	Reverts the operation of a two-stage thermostat to a single-stage thermostat when the second heating stage is not needed. Default: 2.0	(1.0) : One Stage (2.0) : Two Stages
C stage	Reverts the operation of a two-stage thermostat to a single-stage thermostat when the second cooling stage is not needed. Default: 2.0	(1.0) : One Stage (2.0) : Two Stages

Table 2: Installer Configuration Menu (Part 4 of 4)

Parameter Appearing on Display	Description and Default	Selection Options
H lock	Discontinues heating operation in response to the outdoor air temperature. Requires that an outdoor air temperature sensor be installed and connected. Default: 120°F/49°C	Range: -15°F/-26°C to 120°F/49°C adjustable in 5F°/5C° increments
C lock	Discontinues cooling operation in response to the outdoor air temperature. Requires that an outdoor air temperature sensor be installed and connected. Default: -40°F/-40°C	Range: -40°F/-40°C to 95°F/35°C adjustable in 5F°/5C° increments
2/4event⁴	Sets the number of events within a 24-hour period. Default: 2.0	(2.0): Two events (one occupied and one unoccupied) within a 24-hour period (4.0): Four events (two occupied and two unoccupied) within a 24-hour period
Aux cont	Energizes peripheral devices (lighting equipment, exhaust fans, and economizers). Default: n.o.	(n.c.): Contact open = Occupied; contact closed = Unoccupied (n.o.): Contact closed = Occupied; contact open = Unoccupied The contact toggles with the internal Occupied/Unoccupied schedule (or the NSB contact on one of the digital inputs, if used).
Prog rec⁴	Provides the desired occupied temperature either at the start of the occupied schedule or after the occupied schedule begins. Note: Progressive recovery is disabled if either DI1 or DI2 is configured as remote NSB. Default: off	(on): Enabled (provides the desired occupied temperature at the start of the occupied schedule) (off): Disabled (provides the desired occupied temperature after the occupied schedule begins)

1. Setting DI1 or DI2 to RemNSB disables schedules and stops the Schedule menu display. Any other setting enables schedules and the Schedule menu. (T600MSP-3 only)
2. When adjusting the numeric value, press the **UP** or **DOWN** arrow key to change the value by single increments; press and hold the **UP** or **DOWN** arrow key to change the numeric value in increments of ten.
3. When adjusting the temperature, press the **UP** or **DOWN** arrow key to change the value in 0.5F°/0.5C° increments; press and hold the **UP** or **DOWN** arrow key to change the value in 5.0F°/5.0C° increments.
4. T600MSP-3 only

Operation

Programming/Operating the T600MSx-3 Thermostat

Once the thermostat is configured via the Installer Configuration Menu, its operating parameters can be programmed via the Main User Menu. Access this menu by pressing the **MENU** key during normal thermostat operation. The Main User Menu contains the basic operating features of the thermostat.

The Main User Menu also uses Auto Help, which is displayed automatically in the menu when there is a pause in programming activity. To exit Auto Help, continue with the programming selection. When the thermostat is in the Main User Menu and is left unattended for 45 seconds, the menu reverts to the Status Display Menu.

Follow the steps in Table 3 to program the thermostat.

Table 3: Programming the T600MSx-3 Thermostat (Part 1 of 2)

Thermostat Display	Description
RoomTemp 75.0 °F	Press the MENU key while in the Status Display Menu to enter the Main User Menu.
Override schd Y/N	Overrides Unoccupied Setpoints Only Appears if Thermostat is in Unoccupied State See the <i>Enabling Override Schedule</i> section.
Cancel ovrd Y/N	Cancels Override mode.
Temperat set? Y/N	Sets the Temperature Setpoints See the <i>Entering Permanent Temperature Setpoints</i> section.
Sys mode set? Y/N	Selects the System Mode Default: Automatic (auto) See the <i>Selecting the System Mode</i> section.
Fan mode set? Y/N	Selects the Fan Mode Default: Automatic (auto) for T600MSN-3 Smart (smart) for T600MSP-3 See the <i>Selecting the Fan Mode</i> section.

Table 3: Programming the T600MSx-3 Thermostat (Part 2 of 2)

Thermostat Display	Description
Schedule set? Y/N	Sets the Occupied and Unoccupied Time Periods See the <i>Programming the Daily Schedule – Two-Event</i> and <i>Programming the Daily Schedule – Four-Event</i> sections.
Clock set? Y/N	Sets the Day and Time See the <i>Setting the Day and Time</i> section.
Schedule hold? Y/N	Sets a Permanent Hold on the Schedule or Resumes the Schedule See the <i>Setting Schedule Hold</i> section.

Note: Schedule Set and Clock Set are available on T600MSP-3 models only.

Enabling Temporary Override Schedule

Note: The Override Schedule function is available in T600MSN-3 models only when D11 or D12 is configured as remote NSB.

Note: The Override Schedule prompt only appears when in the Unoccupied (Unoccup) or Unoccupied Hold (Unoccup hold) Mode.

The override schedule prompt only appears when the thermostat is in the unoccupied state. This menu selection gives the user the option of overriding the unoccupied setpoints with the occupied setpoints for the amount of time specified under the **TOccTime** parameter. See the *Configuring the T600MSx-3 Thermostat* section.

Note: If D11 or D12 is configured to operate as a remote override contact, this menu is disabled.

To override the unoccupied state while in the Main User Menu:

1. Press the **NO** key to all prompts until the Override Schedule prompt appears. If the thermostat is in the unoccupied state, this is the first prompt.
2. Press the **YES** key to enable the temporary override. The thermostat returns to the Status Display Menu.

When scrolling through the Status Display Menu, Override now appears for the schedule status parameter.

Canceling the Temporary Override

The Cancel Override (Cancel ovrd) prompt only appears when the thermostat is in the unoccupied override mode.

To resume the schedule while in the Main User Menu:

1. Press the **NO** key to all prompts until the **Cancel ovrd** prompt appears. If the thermostat is in the override state, this is the first prompt.
2. Press the **YES** key to resume the programmed schedule.

The thermostat returns to the Status Display Menu.

Entering Permanent Temperature Setpoints

The first prompt appearing in the Main User Menu of the thermostat when in the occupied state is to set the permanent temperature setpoint.

To enter the permanent heating and cooling setpoints for the Occupied and Unoccupied Modes, follow the steps in Table 4. When changing the temperatures, press the keys once to change the temperature in 0.5F°/0.5C° increments; press and hold down the keys to change the temperature in 5.0F°/5.0C° increments.

Table 4: Entering Permanent Temperature Setpoints (Part 1 of 2)

Thermostat Display	Description
RoomTemp 75.0°F	Press the MENU key while in the Status Display Menu to enter the Main User Menu.
Temperat set? Y/N	Press the NO key to all prompts until the temperature setpoint prompt appears on the display (it may be the first prompt). Press the YES key to enter the temperature setting menu.
Cooling set? Y/N	Press the YES key to change the occupied cooling setpoint. Press the NO key to advance to the occupied heating setpoint menu.
Cooling 75.0°F	Press the UP/DOWN arrow keys to set the temperature. Press the YES key to store the value and advance to the next menu.
Heating set? Y/N	Press the YES key to change the occupied heating setpoint. Press the NO key to advance to the unoccupied cooling setpoint menu.

Table 4: Entering Permanent Temperature Setpoints (Part 2 of 2)

Thermostat Display	Description
Heating 68.0°F	Press the UP/DOWN arrow keys to set the temperature. Press the YES key to store the value and advance to the next menu.
Unocc CL set? Y/N	Press the YES key to change the unoccupied cooling setpoint. Press the NO key to advance to the unoccupied heating setpoint.
Unocc CL 80.0°F	Press the UP/DOWN arrow keys to set the temperature. Press the YES key to store the value and advance to the next menu.
Unocc HT set? Y/N	Press the YES key to change the unoccupied heating setpoint. Press the NO key to advance to the temperature display units.
Unocc HT 62.0°F	Press the UP/DOWN arrow keys to set the temperature. Press the YES key to store the value and advance to the next menu.
°F/°C set? Y/N	Press the YES key to set the display units to °F or °C. Press the NO key to advance to the temperature setpoint type menu.
Exit? Y/N	Press the YES key to return to the Status Display Menu or press the NO key to re-enter the temperature setting menu.

Entering Temporary Temperature Setpoints

The temperature setpoints can be changed temporarily for the occupied and unoccupied heating and cooling modes. To temporarily change the setpoint, press the **UP/DOWN** arrow keys to change the temporary setpoint for the current mode of operation.

Note: Whether the thermostat is heating or cooling, the respective setpoint will be temporarily adjusted. To toggle between the temporary heating and cooling setpoints, press the **NO** key while changing the temporary setpoints.

Ending Temporary Temperature Setpoints

The temporary setpoints remain in effect for the duration set in the **TOccTime** parameter or until manually released.

Note: Setting TOccTime to 0.0 hrs prevents the temporary setpoints from taking effect.

To manually release the temporary setpoint, while in the Main User Menu:

1. Press the **NO** key to all prompts until the Temperature set prompt appears. If the thermostat is in the occupied state, this is the first prompt.
2. Press the **YES** key to cancel all temporary setpoints.
3. Press the **MENU** key again and press the **YES** key to exit the Main User Menu.

The setpoint reverts to the Permanent Temperature Setpoint.

Selecting the System Mode

The thermostat has four system modes:

- **Automatic Mode (auto):** Automatic changeover between heating and cooling. This is the default setting.
- **Cooling Mode (cool):** Cooling operation only
- **Heating Mode (heat):** Heating operation only
- **Off Mode (off):** The thermostat is off; however, when frost protection (**Frost pr** parameter) is enabled, the thermostat still calls for heat if the temperature falls below 42°F/5.5°C.

To set the system mode while in the Main User Menu:

1. Press the **NO** key to all prompts until the system mode prompt appears on the display. Press the **YES** key to select the desired system mode.
2. Press the **UP/DOWN** arrow keys to locate the desired system mode. Press the **YES** key to select the desired system mode.
3. Press the **YES** key to return to the Status Display Menu or press the **NO** key to return to the system mode selection menu.

Selecting the Fan Mode

The thermostat has three fan mode settings:

- **On Fan Mode (on):** Energizes the fan all the time for both occupied and unoccupied states, even if the system mode is set to off.
- **Automatic Fan Mode (auto):** Energizes the fan only on a call for heating or cooling, for both occupied and unoccupied states. This is the default setting for T600MSN-3 thermostats.
- **Smart Fan Mode (smart):** Energizes the fan all the time for occupied states, and only on a call for heating or cooling in unoccupied states. This is the default setting for T600MSP-3 thermostats.

To select the fan mode while in the Main User Menu:

1. Press the **NO** key to all prompts until the fan mode prompt appears on the display. Press the **YES** key to set the fan mode.
2. Press the **UP/DOWN** arrow keys to locate the desired fan mode. Press the **YES** key to select the desired fan mode.
3. Press the **YES** key to return to the Status Display Menu or press the **NO** key to return to the fan mode selection menu.

Programming the Daily Schedule – Two-Event

The schedule-setting menu is used to enter the occupied or unoccupied states for each day of the week. The schedule-setting menu reflects either a two- or a four-event schedule per day, based on what was selected in the **2/4event** parameter during the configuration process. If the schedule-setting menu does not reflect a two-event schedule, select two events in the **2/4event** parameter of the Installer Configuration Menu.

When changing the time, press the **UP/DOWN** arrow keys once to change the time in 1-minute increments; press and hold down the keys to change the time in 30-minute increments.

Note: Programming one of the digital inputs to remote NSB disables the menu.

To set the time schedule for a two-event schedule, follow the steps in Table 5. See Table 7, Events 1 and 2, for an example of a two-event office schedule.

Table 5: Programming the Daily Schedule – Two-Event (Part 1 of 2)

Thermostat Display	Description
RoomTemp 75.0°F	Press the MENU key while in the Status Display Menu to enter the Main User Menu.
Schedule set? Y/N	Press the NO key to all prompts until the schedule set prompt appears on the display. Press the YES key to enter the scheduling menu.
Monday set? Y/N	Press the YES key to set the schedule for Monday or press the NO key to advance to Tuesday.
Occupied day? Y/N	Press the YES key to set the occupied start time for Monday or press the NO key to advance to Tuesday. Selecting NO will leave the thermostat in the unoccupied state for the entire day.
Occupied 12:00 AM	Press the UP/DOWN arrow keys to set the occupied start time. Press the YES key to enter the time.
Unoccup 12:00 AM	Press the UP/DOWN arrow keys to set the unoccupied start time. Press the YES key to enter the time.
Tuesday set? Y/N	Press the YES key to set the schedule for Tuesday or press the NO key to advance to Wednesday.
Copy Y/N previous	Press the YES key to copy the schedule from the previous day. Press the NO key to set a different schedule.

Table 5: Programming the Daily Schedule – Two-Event (Part 2 of 2)

Thermostat Display	Description
Wednesda set? Y/N	If the YES key was pressed, the next prompt is for Wednesday. Repeat the procedure for the rest of the days of the week.
Exit? Y/N	After setting the schedule for all the days of the week, following the last entry for Sunday, press the YES key to return to the Status Display Menu or press the NO key to start again at Monday.

Programming the Daily Schedule – Four-Event

The schedule-setting menu is used to enter the occupied and unoccupied states for each day of the week. The schedule-setting menu reflects either a two- or four-event schedule per day, based on what was selected in the *2/4event* parameter during the configuration process. If the schedule-setting menu does not reflect a four-event schedule, select four events in the *2/4event* parameter of the Installer Configuration Menu.

When changing the time, press the **UP/DOWN** arrow keys once to change the time in 1-minute increments; press and hold down the keys to change the time in 30-minute increments.

Note: Programming one of the digital inputs to remote NSB disables the menu.

To set the time schedule for a four-event schedule, follow the steps in Table 6. See Table 7 for an example of a four-event office schedule.

Table 6: Programming the Daily Schedule – Four-Event (Part 1 of 2)

Thermostat Display	Description
RoomTemp 75.0°F	Press the MENU key from the Status Display Menu to enter the Main User Menu.
Schedule set? Y/N	Press the NO key to all prompts until the schedule set prompt appears on the display. Press the YES key to enter the scheduling menu.

**Table 6: Programming the Daily Schedule –
Four-Event (Part 2 of 2)**

Thermostat Display	Description
<div style="border: 1px solid black; padding: 5px; width: fit-content;">Monday set? Y/N</div>	Press the YES key to set the schedule for Monday or press the NO key to advance to Tuesday.
<div style="border: 1px solid black; padding: 5px; width: fit-content;">Occupied day? Y/N</div>	Press the YES key to set the occupied start time for Monday or press the NO key to advance to Tuesday. Selecting NO will leave the thermostat in the unoccupied state for the entire day.
<div style="border: 1px solid black; padding: 5px; width: fit-content;">Occupied 12:00 AM</div>	Press the UP/DOWN arrow keys to set the first occupied start time. Press the YES key to enter the time.
<div style="border: 1px solid black; padding: 5px; width: fit-content;">Unoccup 12:00 AM</div>	Press the UP/DOWN arrow keys to set the first unoccupied start time. Press the YES key to enter the time.
<div style="border: 1px solid black; padding: 5px; width: fit-content;">Occupie2 12:00 AM</div>	Press the UP/DOWN arrow keys to set the second occupied start time. Press the YES key to enter the time.
<div style="border: 1px solid black; padding: 5px; width: fit-content;">Unoccup2 12:00 AM</div>	Press the UP/DOWN arrow keys to set the second unoccupied start time. Press the YES key to enter the time.
<div style="border: 1px solid black; padding: 5px; width: fit-content;">Tuesday set? Y/N</div>	Press the YES key to set the schedule for Tuesday or press the NO key to advance to Wednesday.
<div style="border: 1px solid black; padding: 5px; width: fit-content;">Copy Y/N previous</div>	Press the YES key to copy the schedule from the previous day. Press the NO key to set a different schedule.
<div style="border: 1px solid black; padding: 5px; width: fit-content;">Wednesda set? Y/N</div>	If the YES key was pressed, the next prompt is for Wednesday. Repeat the procedure for all days of the week.
<div style="border: 1px solid black; padding: 5px; width: fit-content;">Exit? Y/N</div>	After setting the schedule for all the days of the week, following the last entry for Sunday, press the YES key to return to the Status Display Menu or press the NO key to start again at Monday.

Table 7: Four-Event Office Schedule

Event	Event 1		Event 2		Event 3		Event 4	
	Occupied		Unoccupied		Occupied 2		Unoccupied 2	
	Cool	Heat	Cool	Heat	Cool	Heat	Cool	Heat
	72°F (22°C)	70°F (21°C)	80°F (27°C)	62°F (17°C)	72°F (22°C)	70°F (21°C)	80°F (27°C)	62°F (17°C)
Monday	7:00 A.M.		5:00 P.M.		12:00 P.M. ¹		12:00 P.M. ¹	
Tuesday	7:00 A.M.		5:00 P.M.		12:00 P.M. ¹		12:00 P.M. ¹	
Wednesday	7:00 A.M.		5:00 P.M.		12:00 P.M. ¹		12:00 P.M. ¹	
Thursday	7:00 A.M.		5:00 P.M.		7:00 P.M.		10:30 P.M.	
Friday	7:00 A.M.		5:00 P.M.		7:00 P.M.		10:30 P.M.	
Saturday	12:00 P.M. ¹		12:00 P.M. ¹		12:00 P.M. ¹		12:00 P.M. ¹	
Sunday	12:00 P.M. ¹		12:00 P.M. ¹		12:00 P.M. ¹		12:00 P.M. ¹	

1. Programming different events to the same time for that day cancels those events and leaves the thermostat in the unoccupied state.

Setting the Day and Time

Upon initial power up (or after a power loss of greater than 6 hours), the thermostat shows a *SetClock* alarm on its display. As the thermostat scrolls through the Status Display Menu, the *SetClock* message causes the backlight to light up until the clock is set.

When changing the time, press the **UP/DOWN** arrow keys once to change the time in 1-minute increments; press and hold down the keys to change the time in 30-minute increments.

To set the clock while in the Main User Menu:

1. Press the **NO** key to all prompts until the clock set prompt appears on the display. Press the **YES** key to enter the clock set menu.
2. Press the **YES** key to set the time or press the **NO** key to advance to the day set menu.
3. Press the **UP/DOWN** arrow keys to adjust the time. When the correct time is displayed, press the **YES** key to store the time.
4. Press the **YES** key to enter the day set menu or press the **NO** key to enter the clock format menu.
5. Press the **UP/DOWN** arrow keys to adjust the day. When the correct day is displayed, press the **YES** key to store the day.
6. Press the **YES** key to choose the time format or press the **NO** key to access the Main User Menu exit prompt.
7. Press the **UP/DOWN** arrow keys to select the desired time format. Press the **YES** key to enter the format.

8. Press the **YES** key to return to the Status Display Menu or press the **NO** key to return to the time set menu.

When the thermostat scrolls through the day and time, the new day and time should show on the display and no alarm or backlight should be present. If the day or time is incorrect, repeat the *Setting the Day and Time* procedure.

Setting Schedule Hold

The schedule hold menu is used to set a permanent hold on the internal scheduling or resume the schedule. The permanent hold is typically used for non-scheduled events that extend for long periods of time.

Note: The Schedule Hold menu is also displayed if DI1 or DI2 is configured for remote NSB.

The Override Schedule function is available in T600MSN-3 models only if DI1 or DI2 is configured for remote NSB.

The following selections are available in the schedule hold menu:

- **Permanent Occupied Hold (occ hold):** This selection puts the thermostat into a permanent occupied state via the occupied setpoints. *Occupied hold* appears in the Status Display Menu when this selection is active.
- **Permanent Unoccupied Hold:** This selection puts the thermostat into a permanent unoccupied state via the unoccupied setpoints. *Unoccup hold* appears in the Status Display Menu when this selection is active.

- **Resume:** This selection cancels the permanent hold and enables the regular program schedule.

To enable or cancel the permanent hold feature while in the Main User Menu:

1. Press the **NO** key to all prompts until the schedule hold prompt appears on the display. Press the **YES** key to set the schedule hold type.
2. Press the **UP/DOWN** arrow keys to locate the desired permanent hold type (or *resume* schedule). Press the **YES** key to enter the selection.
3. Press the **YES** key to return to the Status Display Menu or press the **NO** key to change the schedule hold selection again.

Accessories

All the accessories in Table 8 include mounting hardware; contact the nearest Johnson Controls® representative to order any of these parts.

Note: Review the technical specifications of the accessories prior to their use in an application.

Repair Information

If the T600MSx-3 thermostat fails to operate within its specifications, replace the unit. For a replacement thermostat, contact the nearest Johnson Controls representative.

Table 8: Accessories (Order Separately)

Code Number	Description
SEN-600-1	Remote Indoor Air Temperature Sensor
SEN-600-4	Remote Indoor Air Temperature Sensor with Occupancy Override and LED
TE-6361M-1¹	Duct Mount Air Temperature Sensor
TE-636S-1¹	Strap-on Temperature Sensor

1. Additional TE-636xx-x Series 10k ohm Johnson Controls Type II Thermistor Sensors are available; refer to the *TE-6300 Series Temperature Sensors Product Bulletin (LIT-216320)* for more details.

Table 9: Display Messages

Display	Function
Service	Indicates that there is a service alarm in accordance with the programmable Digital Inputs (DI1 or DI2)
Filter	Indicates that the filter(s) is dirty in accordance with the programmable Digital Inputs (DI1 or DI2)
Frost ON	Indicates that the heating is energized by the low limit frost protection room temperature setpoint.
SetClock	Indicates that there has been a power failure greater than 6 hours and the clock needs to be reset. (T600MSP-3 only.)

Technical Specifications

T600MSx-3 Series Thermostats

Power Requirements		19 to 30 VAC, 50/60 Hz, 2 VA (Terminals RC and C) at 24 VAC Nominal, Class 2 or Safety Extra-Low Voltage (SELV)
Relay Contact Rating		30 VAC, 1.0 A Maximum, 3.0 A In-Rush, Class 2 or SELV
Digital Inputs		Voltage-Free Contacts across Terminal C to Terminals DI1 and DI2
Wire Size		18 AWG (1.0 mm Diameter) Maximum, 22 AWG (0.6 mm Diameter) Recommended
Temperature Sensor Type		Local 10k ohm Type II Negative Temperature Coefficient (NTC) Thermistor
Temperature Range	Backlit Display	-40.0°F/-40.0°C to 122.0°F/ 50.0°C in 0.5° Increments
	Heating Control	40.0°F/4.5°C to 90.0°F/32.0°C
	Cooling Control	54.0°F/12.0°C to 100.0°F/38.0°C
Accuracy	Temperature	±0.9F°/±0.5C° at 70.0°F/21.0°C Typical Calibrated
Minimum Deadband		2F°/1C° between Heating and Cooling
Ambient Conditions	Operating	32 to 122°F (0 to 50°C); 95% RH Maximum, Noncondensing
	Storage	-22 to 122°F (-30 to 50°C); 95% RH Maximum, Noncondensing
Compliance	United States	UL Listed, File E27734, CCN XAPX, Under UL 873, Temperature Indicating and Regulating Equipment
		FCC Compliant to CFR 47, Part 15, Subpart B, Class A
	Canada	UL Listed, File E27734, CCN XAPX7, Under CAN/CSA C22.2 No. 24, Temperature Indicating and Regulating Equipment
		Industry Canada, ICES-003
Europe	CE Mark, EMC Directive 89/336/EEC	
Australia and New Zealand	C-Tick Mark, Australia/NZ Emissions Compliant	
Shipping Weight		0.75 lb (0.34 kg)

The performance specifications are nominal and conform to acceptable industry standards. For application at conditions beyond these specifications, consult the local Johnson Controls office. Johnson Controls, Inc. shall not be liable for damages resulting from misapplication or misuse of its products.



Controls Group
507 E. Michigan Street
Milwaukee, WI 53202

All marks herein are the marks of their respective owners.
© 2006 Johnson Controls, Inc.